

ACR 系列谐波仪表

ACR Series Harmonic Meters

安装使用说明书 V1.3
Installation and operation instruction V1.3

安科瑞电气股份有限公司

ACREL CO.,LTD

申 明

DECLARATION

版权所有，未经本公司之书面许可，此手册中任何段落、章节内容均不得被摘抄、拷贝或以任何形式复制、传播，否则一切后果由违者自负。

本公司保留一切法律权利。

本公司保留对本手册所描述之产品规格进行修改的权利，恕不另行通知。订货前，请垂询当地代理商以获悉本产品的最新规格。

No part of this publication may be reproduced, stored in a retrieval system, or transmitted in any form by any means, electronic, mechanical photocopying, recording, or otherwise without prior permission of Acrel. All rights reserved.

This company reserve power of revision of product specification described in this manual, without notice. Before ordering, please consult local agent for the latest specification of product.

目 录

CONTENTS

1 概述 General.....	- 1 -
2 产品规格及功能特点 Specification and features	- 1 -
2.1 系列产品规格 Series Products specification	- 1 -
2.2 系列产品辅助功能 auxiliary functions of series products	- 3 -
3 技术参数 Technical parameter	- 6 -
4 安装接线说明 Instruction of installing connection	- 7 -
4.1 安装尺寸 installing size	- 7 -
4.2 接线方法 Method of connection	- 8 -
5 包装 Package	- 10 -
6 工程施工注意事项 Notice in engineering construction	- 10 -
6.1 电压输入 Voltage input	- 10 -
6.2 电流输入 Current input	- 10 -
6.3 通讯接线 Communication connection	- 11 -
7 操作说明 Operation description	- 12 -
7.1 ACR220ELH /ACR320ELH 操作指南 Operating guide.....	- 12 -
7.2 ACR230ELH/ACR330ELH 操作指南 Operation guide.....	- 26 -
8 通讯说明 Communication description	- 40 -
8.1 简介 General.....	- 40 -
8.2 通讯地址表 Communication Address Table	- 40 -
8.3 通讯值与实际值对应关系(约定 Val_t 为通讯读出值, Val_s 为实际值)Communication reading value Vs actual value(Take Val_t as Communication reading value,Val_s as actual value).....	- 55 -
9 DL/T-645 通讯指南 Communication Guideline	- 58 -
9.1 DL/T645-1997 协议简述 DL/T645-1997 protocol overview	- 58 -
9.2 传输方式 Transmission mode	- 59 -
9.3 协议 Protocol.....	- 59 -
10 平均值、极值、不平衡度相关说明 Explanation of average value、extremum、unbalance.....	- 65 -
10.1 按键操作指南 Key operation guide.....	- 65 -
10.2 通讯说明 Communication description	- 67 -
11 以太网设置 Ethernet network settings.....	- 76 -
11.1 网络设置 Network settings	- 76 -
11.2 WEB 网页配置 WEB page configuration	- 77 -
11.3 仪表设置 Instrument settings	- 78 -
11.4 ModScan32 设置 ModScan32 settings	- 79 -

1 概述 General

ACR 系列谐波表包括 ACR220ELH,ACR230ELH,ACR320ELH,ACR330ELH 等多款仪表,是本公司按 IEC 标准设计,与国际先进技术同步的综合电力监控仪表。

该系列产品具有三相交流电量测量、复费率电能计量、四象限电能计量、谐波分析、电网质量分析、遥信输入、遥控输出以及网络通讯等功能,其中 ACR230ELH/ACR330ELH 同时还具有电网波形实时跟踪显示和 SOE 事件记录功能,主要用于对电网供电质量的综合监控诊断及电能管理。

ACR Harmonic meters include multiple products,such as ACR220ELH,ACR230ELH,ACR320ELH,ACR330ELH etc.The integrated electric power monitoring meters are developed byACREL,conforming to IEC standard,synchronized with the international advanced technology.

They have many functions such as full-scale three Phase AC electric parameter measurement,multi-rate electric energy metering,four-quadrant electric energy metering,harmonic analysis,electric network quality analysis,remote signaling input,remote control Output,Network Communication function etc.ACR230ELH/ACR330ELH has electric network waveform real time tracking display and SOE Event record function,mainly using for integrated monitoring and power management of electricity quality of electric network.

2 产品规格及功能特点 Specification and features

2.1 系列产品规格 Series Products specification

型号 Type	ACR220ELH	ACR230ELH	ACR320ELH	ACR330ELH
功能特性 Functional performance				
显示方式 display mode				
	LCD (字段式) LCD(Field)	LCD (点阵式) LCD(Dot-matrix)	LCD (字段式) LCD(Field)	LCD (点阵式) LCD(Dot-matrix)
实时测量 Real-time measurement				
电流/电压/频率/功率因数 Current/voltage/frequency/power factor	√	√	√	√
中性线电流 Neutral current	×	×	可选 optional	可选 optional
有功/无功/视在功率 Active power/Reactive power/Apparent power	√	√	√	√
四象限电能计量 Four-quadrant electric energy metering	√	√	√	√

最大需求 maximum demand	√	√	√	×
复费率电能计量 KWH Multi-rate	√	√	√	√
电能质量监测 Power quality detection				
分次谐波 Sub-harmonic	√(2-63)	√(2-63)	√(2-63)	√(2-63)
总谐波含量 (THD) Total Harmonic Distortion (THD)	√	√	√	√
电压波峰系数 (CF) Crest factor(CF)	×	√	×	√
电话波形因子 (THFF) telephone waveform factor (THFF)	×	√	×	√
电流 K 系数 (KF) Current K coefficient(KF)	×	√	×	√
电压电流不平衡度 (UF) Unbalance factor(UF)	√	√	√	√
电压角度 ^注 Voltage angle ^{note}	√	√	√	√
电流角度 ^注 Current angle ^{note}	×	√	×	√
峰值电压 Peak Voltage	×	√	×	√
电压电流量 Voltage/current sequence	×	√	×	√
波形跟踪显示 Waveform tracking display	×	√可调 tunable	×	√可调 tunable
数据记录 Data record				
事件记录 Event record	√	√	√	√
报警 Alarm	√	√	√	√
内置时钟 Clock embedded	√	√	√	√
通讯 Communication				
RS485 接口 RS485interface	Modbus 协议 Modbus Protocol	√	√	√
	DL/T-645 规约 DL/T-645 statute	√	√	√
以太网 Ethernet	√	×	×	×
Profibus	√	√	√	√

注：3相4线时，电压角度、电流角度才有效。

Note: Only in 3 phase 4 wire system can voltage angle and current angle be effective.

2.2 系列产品辅助功能 auxiliary functions of series products

仪表型号 type	外形 shape	可选功能 ^{注1、注6} Optional functions	有功脉冲 active pulse	无功脉冲 Reactive pulse	接线方式 ^{注3} Connection mode
ACR220ELH ACR230ELH	96 方形 square	1、无 none	√	√	C2
		2、2DI2DO ^{注4}			A1+B1
		3、4DI	√		A2+C1
		4、4DI2DO	√		A2+B3+C1
					A2+B1
		5、4DI2DO2M+C ^{注5}	√	√	A2+B1+D2+C2
		6、5DI	√		A3+C1
		7、2M	√	√	D2+C2
		8、CP ^{注2}			见 Profibus 通讯
9、4DI+CE(以太网 Ethernet)	√		A2+C1		
ACR320ELH ACR330ELH	42 方形 square	1、无 none	√	√	C2
		2、4DI2DO2M	√	√	A2+B3+D2+C2
		3、4DI3DO	√		A2+B6+C1
		4、4DI3DO+C ^{注5}			
		5、4DI4DO	√		A2+B5+C1
					A2+B2
		6、8DI	√	√	A4+C3
		7、8DI4DO			A4+B4
		8、8DI2DO	√	√	A4+B3+C3
		9、4M	√	√	D1+C2
10、CP ^{注2}			见 Profibus 通讯		

注 1：可选功能中，DI:表示开关量输入；DO:表示开关量输出；M:表示模拟量输出，CP:表示 Profibus 接口；CE:表示以太网通讯(如:4DI3DO+C表示四路开关量输入+三路开关量输出+两路 RS485 通讯)。

注 2：Profibus 与 RS485 通讯不可同时选择，但可与其它所有功能任意配合选择。

注 3：接线方法是几种可选功能的组合，例：订货型号为 ACR320ELH/KC(8DI4DO),辅助功能接线

Note 1: among the optional functions, DI: switch input; DO: switch output, M: analog output, CP: Profibus interface, CE: Ethernet interface (e.g.: 4DI3DO+C indicates four-way switch input + three-way switch output + two-way RS485 communication).

Note 2: Profibus and RS485 communication can not be enabled at the same time; but it can be randomly compatible with all other functions.

方式为：A4+B4。

Note 3: the wiring method is the combination of

several selectable functions, e.g.: order model ACR320ELH/KC(8DI4DO), auxiliary function

注 4: 如带报警功能, 占 DO 中的一组触点。

Note 4: e.g. having alarm function, occupying one

注 5: 当仪表可选功能中带+C 时, 表示增加 1 路 RS485 通讯(仪表标配一路 RS485 通讯)。

注 6: 各辅助功能的接线方式详见第五页。

注 7: 当选择 CE 以太网通讯时, 只能共选功能为 4DI+CE+一路 RS485 通讯+一路脉冲。

wiring mode: A4+B4.

set of DO contacts.

Note 5: when the instrument selectable function has +C, it means addition of 1-way RS485 communication (one-way RS485 communication in terms of standard instrument configuration).

Note 6: details of wiring mode of auxiliary functions given in page 5.

Note 7: when CE(Ethernet) function is selected, the only combination is 4DI+CE+ one-way RS485 communication +one pulse.

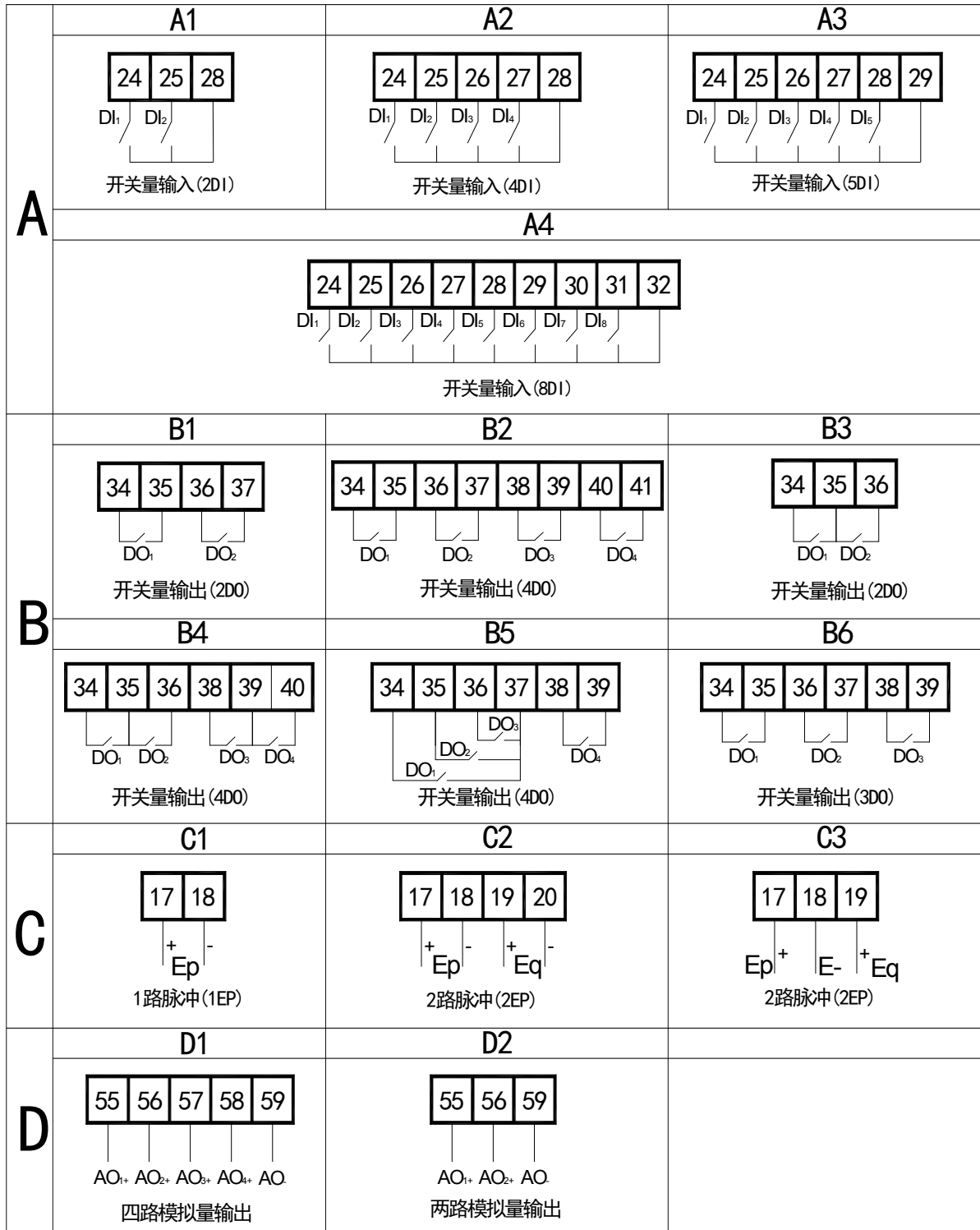

开关量输入 Digital input

开关量输出 Digital output

1路脉冲 1-way pulse

2路脉冲 2-way pulse

四路模拟量输出 Four-way analog quantity output

两路模拟量输出 Two-way analog quantity output

3 技术参数 Technical parameter

技术参数 Technical parameter		指标 Value
输入 Input	网络 Net work	三相三线、三相四线； 3-phase 3-wire,3-phase 4 wire
	频率 Frequency	45~65Hz；
	电压 Voltage	额定值 Rating: AC 57.7V/100V(100V)、220V/380V(400V)、 380V/660V(660V) ；
		过负荷: 1.2 倍额定值 (连续)；2 倍额定值/1 秒； Overload:1.2-fold rating(continuous);2-fold rating/1second
		功耗: < 0.2VA (每路)； Consumption:<0.2VA
	电流 Current	额定值 Rating: AC 1A、5A；
过负荷: 1.2 倍额定值 (连续)；10 倍额定值/1 秒； Overload:1.2-fold rating(continuous);10-fold rating/1 second		
功耗: < 0.2VA (每路)； Consumption:< 0.2VA		
输出 Output	电能 Electric energy	输出方式: 集电极开路的光耦脉冲； Output mode:Open-collector photocoupler pulse 脉冲常数 Pulse constant: 4000imp/kWh(5A)、8000imp/kWh(1A), 详见接线图 See wiring diagram；
	通讯 Communication	RS485 接口、Modbus-RTU 协,Profibus 协议,DLT645 规约 RS485 interface,Modbus-RTU Protocol;Profibus protocol,DL/T645 protocol
开关量输入 Switching input		干接点输入, 内置电源; Dry contact input,built-in power supply
开关量输出 Switching output		输出方式: 继电器常开触点输出; Output mode:Relay NO contact output 触点容量 Contact capacity: AC 250V/3A DC 30V/3A
测量精度 Measuring accuracy		频率 0.05Hz、电压电流 0.2 级、无功电能 1 级、其它 0.5 级; Frequency 0.05HZ,voltage and current level 0.2 class, reactive electric energy 1 class,other 0.5class
电源 Power supply		AC/DC 85~270V; ACR230ELH/ACR330ELH 点阵式液晶 功耗≤6VA (不包括变送输出); ACR230ELH/ACR330ELH dot-matrix LCD Consumption≤6VA(without transmission output) ACR220ELH/ACR320ELH 字段式液晶 功耗≤4VA; ACR220ELH/ACR320ELH Field LCD Consumption≤4VA

安全性 Safety	工频耐压 Power-frequency withstand voltage	外壳与辅助电源、各输入、输出端子组之间的工频耐压为 AC 4kV/1min; Power frequency withstand voltage between enclosure, auxiliary power and input and output terminal is AC 4kV/1min; 辅助电源与各输入端子、各输出端子组之间的工频耐压为 AC 2kV/1min; Power frequency withstand voltage between auxiliary power and input and output terminal is AC 2kV/1min; 电压输入与其他输入输出端子组之间的工频耐压为 AC 2kV/1min; Power frequency withstand voltage between voltage input and other input and output terminal is AC 2kV/1min; 电流输入与其他输入输出端子组之间的工频耐压为 AC 2kV/1min; Power frequency withstand voltage between current input and other input and output terminal is AC 2kV/1min; 继电器输出与其他输入输出端子组之间的工频耐压为 AC 2kV/1min; Power frequency withstand voltage between relay output and other input and output terminal is AC 2kV/1min; 开关量输入、通讯、模拟量输出、脉冲输出各端子组之间的工频耐压为 AC 1kV/1min; Power frequency withstand voltage between switch volume input and communication and analog output and pulse output terminal is AC 1kV/1min;
	绝缘电阻 Insulation resistance	输入、输出端对机壳>100MΩ; Input,Output terminal to housing>100MΩ
环境 Environment	工作温度 Working temperature: -10℃~+55℃; 储存温度 Storage temperature: -20℃~+70℃; 相对湿度 Relative humidity: ≤95% 不结露; 海拔高度 Altitude: ≤2500m;	

4 安装接线说明 Instruction of installing connection

4.1 安装尺寸 installing size

ACR220ELH/ACR230ELH

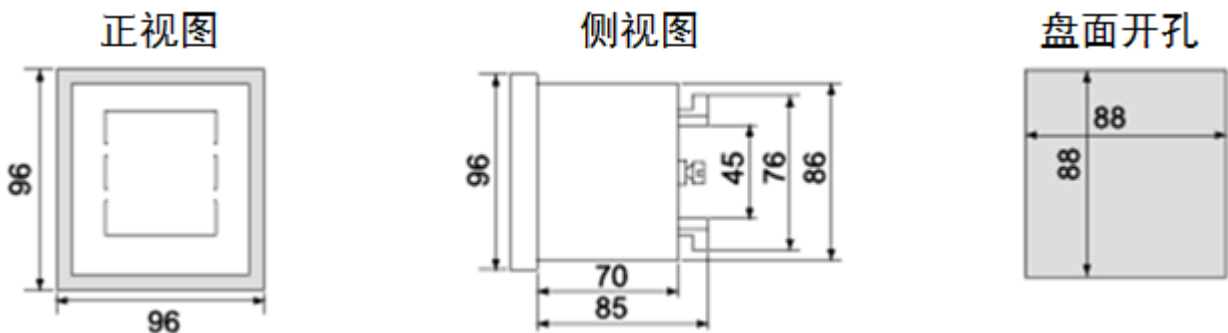

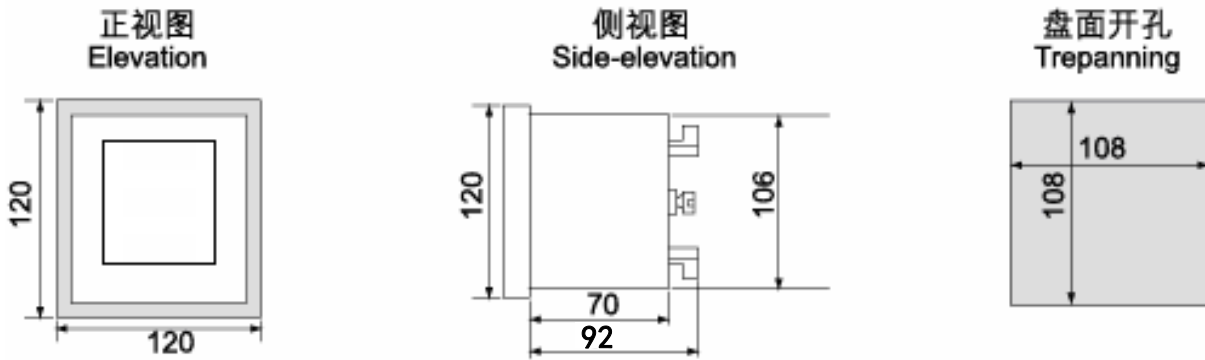

4.2 接线方法 Method of connection

根据不同的设计要求，推荐在电源、电压输入端子增加保险丝 (BS88 2A gG) 以满足相关电气规范的安全性要求。

According to varied design requirements, power and voltage input terminals are recommended with fuse (BS88 2A gG) to meet with the safety performance requirements of prevailing electric codes.

4.2.1 仪表信号端子接线方法

信号端子：“5，6，7，8，9，10”为输入电流信号的端子号；“1，2，3，4”为输入电压信号的端子号；

4.2.1 Method of connection for signal terminal of meter

signal terminal: Terminal number of current input signal as “5, 6, 7, 8, 9, 10”; Terminal number of voltage input signal as “1, 2, 3, 4” ;

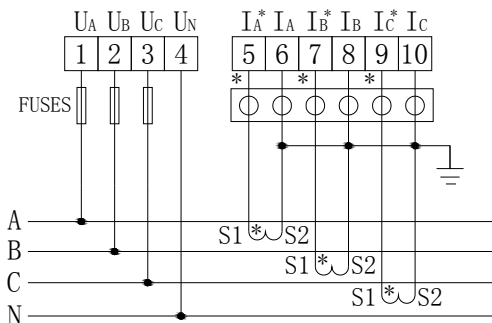

三相四线3CT

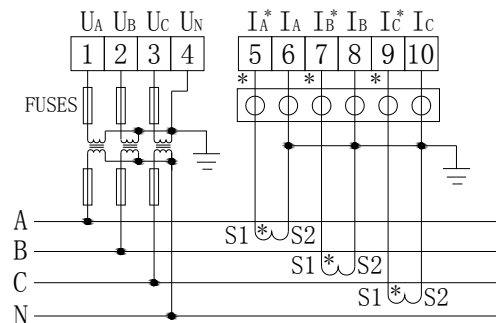

三相四线3PT、3CT

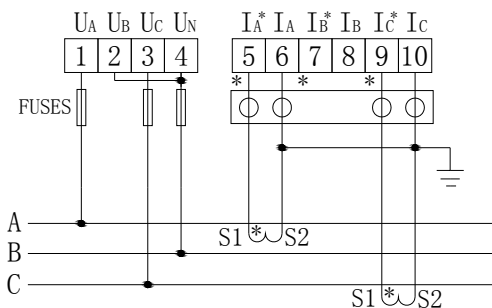

三相三线2CT

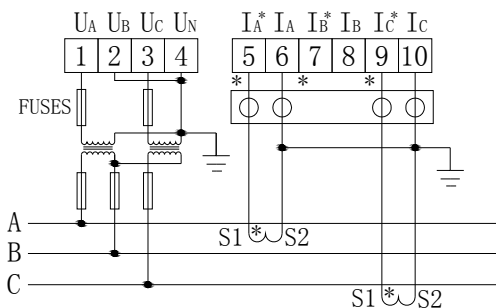

三相三线2PT、2CT

注：○ ○ ○ ○ ○ ○ 为用于CT二次侧短接的试验端子

“44, 45”为中性线电流输入的端子号。

"44, 45" represents the input terminal number of the neutral line current.

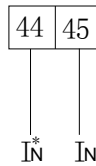

4.2.2 仪表辅助电源、通信端子接线方法

仪表辅助电源及通信端子：“12, 13”为辅助电源端子号，“21,22”为通讯端子号，“60, 61”为第 2 路通讯端子号。

4.2.2 Instrument auxiliary power and communication terminal wiring method

Instrument auxiliary power and communication terminal: "12, 13" auxiliary power terminal number, "21, 22" communication terminal number, "60, 61" represents the second way communication terminal number.

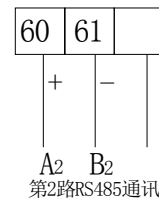
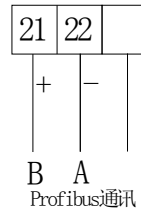
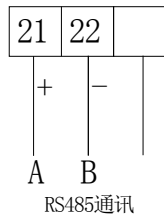
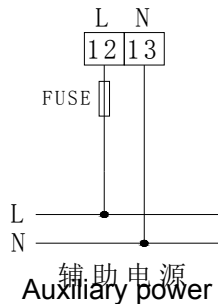

关于通讯部分的接线实例如下图所示：

The wiring example of the communication part is shown in figure below:

正确接线方式：通讯电缆屏蔽层接大地。

Correct wiring mode: communication cable shielding is bonded to earth.

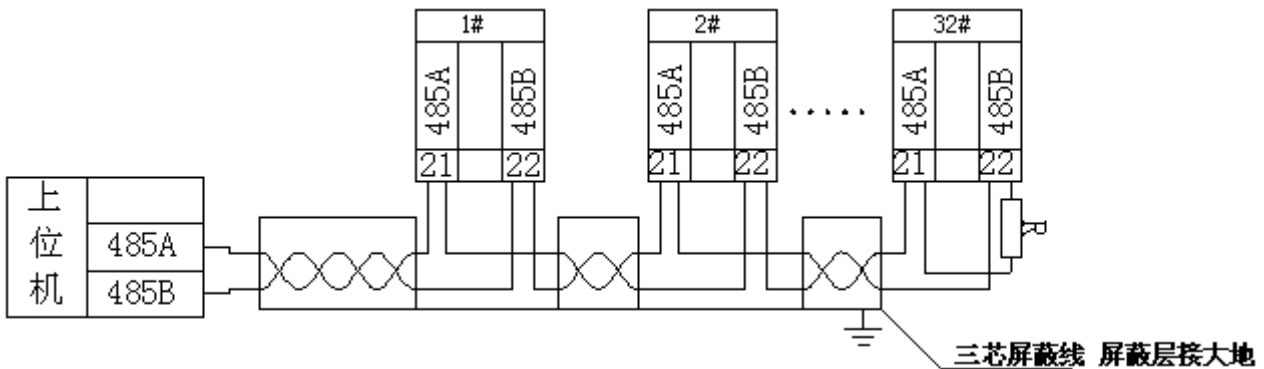

Three-core shielded line/shielding layer is connected with ground.

建议最末端仪表的 A、B 之间加匹配电阻，阻值范围为 120Ω~10 kΩ。

It's recommended that the matching resistance shall be added between the foremost and instruments A, B and the rated resistance range is 120Ω~10 kΩ.

注：当仪表带 Profibus 功能时，与之相关的通信配置、GSD 文件，请详见随仪表附带的光盘。

Note: when the instrument has Profibus function, details of the related communication configuration

and GSD files are given in the accompanying disc of the instrument.

5 包装 Package

包装内含下列项目:主机 (含插拔式端子排)、安装支架、出厂检验报告、合格证 (防伪标签)、安装使用说明书。

The package include following items:Principal

在打开产品包装时, 请仔细检查是否有损坏, 如有任何损坏请及时通知 ACREL 公司或代理商, 并请保留损坏的外包装, 本公司将及时予以更换。

(including plug-in group terminal blocks),installing supporter,delivery inspection report,certificate(anti-forging tag),installation and operation instruction.

When unwrapping the package,check carefully for damage,if any,please inform ACREL company or agent,and keep the damaged external packing for inspection,if it is responsibility of ACREL company or agent,will replace it in time.

6 工程施工注意事项 Notice in engineering construction

6.1 电压输入 Voltage input

输入电压应不高于产品的额定输入电压 (100V 或 400V 或 660V) 的 120%, 否则应使用 PT; 在电压输入端须安装 1A 保险丝; 需根据产品的 PT 接线方式来设定产品的接线方式, 方法如下:

Input Voltage shall not be greater than 120% of rated input Voltage (100V or 400V or 660V), otherwise, using PT shall be considered;On voltage input terminal ,1A fuse shall be installed; Set product connection mode as per the product PT connection mode,shown as follows:

接线方式 Connection mode	选择 Selection
2 元件 2component	3P3L
3 元件 3component	3P4L

6.2 电流输入 Current input

标准额定输入电流为 1A 或 5A, 要求使用外部 CT (建议使用接线排, 不要直接接 CT, 以便于拆装);

要确保输入电流与电压相对应, 相序一致, 方向一致;

如果使用的 CT 回路上连有其它仪表, 接线应采用串接方式;

去除产品的电流输入连线之前, 一定要先断开 CT 一次回路或者短接二次回路!

Standard rated input current is 1A or 5A,the external CT shall be used(Advising to use the line bank,instead of connecting CT directly,to facilitate dismantling);Ensure input current matching with voltage,phase sequence is identical,direction is identical; if the used CT connecting with other meter, connection shall adopt tandem connection mode. Before removing product's current input connection,firstly, cut off CT primary circuit or shorted secondary circuit!

6.3 通讯接线 Communication connection

仪表提供异步半双工 RS485 通讯接口，采用 MODBUS-RTU 协议，各种数据信息均可在通讯线路上上传送。理论上在一条线路上可以同时连接多达 128 个网络电力仪表，每个网络电力仪表均可设定其通讯地址（Addr）。通讯连接建议使用屏蔽双绞线，线径不小于 0.5mm^2 。布线时应使通讯线远离强电电缆或其他强电场环境。

This series meter provides asynchronism half duplex RS485 Communication interface,adopts MODBUS-RTU protocol,various data information may be transmitted on the Communication line. Theoretically,on the same line,meters up to 128 may be connected at the same time ,each meter can set up its Communication address(ADDR).Communication connection is recommended to use shielded twisted pair wire,its linear diameter is no less than 0.5mm^2 ,when wiring,the Communication line shall be far away from strong current cable or other strong electric field environment.

7 操作说明 Operation description

7.1 ACR220ELH /ACR320ELH 操作指南 Operating guide

7.1.1 按键功能说明 Button function description

SET 键 SET	<p>测量模式下，连续按该键 4 次进入编程模式，仪表提示输入密码 CODE，输入正确密码（0001）后，可对仪表进行编程设置；</p> <p>Under measuring mode,press this button in succession for four(4)times to enter the programming mode,meter prompt password input CODE,after type in correct password (0001)to set up meter programming;</p> <p>编程模式下，用于返回上一级菜单</p> <p>Under programming mode,this button is used for return to previous menu</p>
左键 Left	<p>测量模式下，按该键对显示项目向上翻页；</p> <p>Under measuring mode,press this button can page up the display items;</p> <p>编程模式下，用于同级菜单的四位数循环移位（被选中位处于闪烁状态）</p> <p>Under programming mode,this button is used for 4-bitcircular shift of the same menu(the bit selected is in flickering)</p>
右键 Right	<p>测量模式下，按该键对显示项目向下翻页；</p> <p>Under measuring mode,press this button can page down the display items;</p> <p>编程模式下，用于同级菜单的所选位的数值修改（可修改位处于闪烁状态；修改范围为“0—9”）</p> <p>Under programming mode,this button is used for numerical value revising of selected bit of the same menu(the bit revising is in flickering;revising range as"0-9")</p>
回车键 Enter	<p>编程模式下，用于确认菜单项目的选择和参数的修改</p> <p>Under programming mode,this button is used for confirming selection of menu item and revision of parameter</p>

SET 键循环切换显示 如下图所示：

Set circular switching is displaying in below diagram:

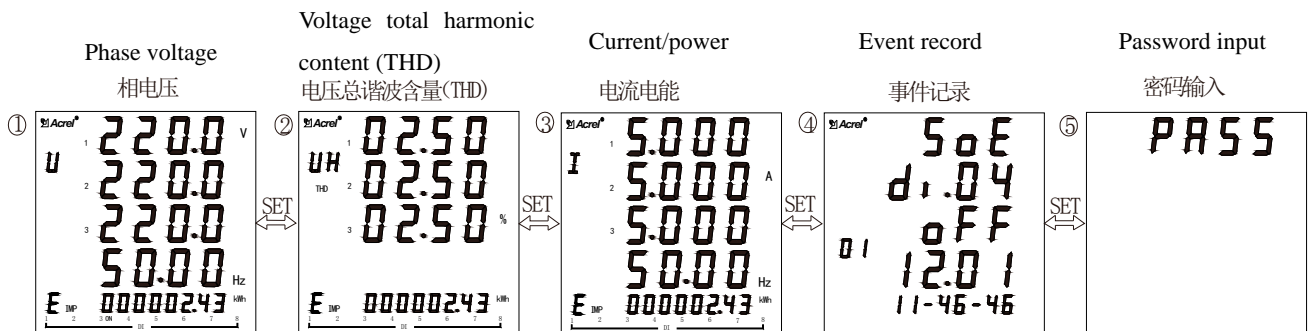

注：以上各 SET 循环界面下文中用①，②，③，④，⑤表示；无事件记录功能时④界面不显示。

Note:Above SET circular interface is shown as①，②，③，④，⑤ respectively,During the absence of event log function, ④interface doesn't show.

7.1.2 仪表开机瞬间显示为仪表版本信息

7.1.2The first displaying information after starting is the meter version information

仪表开机瞬间显示为仪表版本信息，之后即显示相电压或者线电压界面。

The first displaying information after starting is the meter version information,then is the Phase voltage or line voltage.

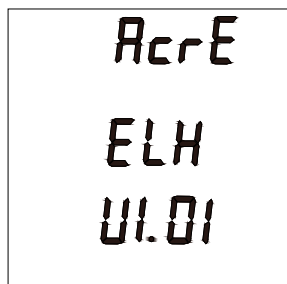

7.1.3 测量参数

I 电力参数 power parameter

A:对三相四线系统,仪表上电后显示①相电压,按左、右键可如下图切换显示其它界面:相电压 \longleftrightarrow 线电压 \longleftrightarrow 电流 \longleftrightarrow 总功率(功率因数) \longleftrightarrow 时间 \longleftrightarrow 最大需量 \longleftrightarrow 有功功率 \longleftrightarrow 无功功率 \longleftrightarrow 视在功率 \longleftrightarrow 功率因数。

7.1.3 Measuring parameter

A:For three phase four wire system,after power up,the meter display:①Phase voltage,press the Left or Right button can switch and display other interface as following:Phase voltage \longleftrightarrow Line voltage \longleftrightarrow Current \longleftrightarrow Total



power(power factor) \longleftrightarrow Time \longleftrightarrow
Maximum demand \longleftrightarrow Active power \longleftrightarrow Reactive power \longleftrightarrow Apparent power \longleftrightarrow power factor.

注: 相电压界面按 ENTER 键进入电压角度界面。

B: 对三相三线系统,仪表上电后显示“线电压”,按左、右键可如下图切换显示其它界面:线电压 \longleftrightarrow 电流 \longleftrightarrow 总功率(功率因数) \longleftrightarrow 时间 \longleftrightarrow 最大需量。

B:For three phase three wire system,after power up,the meter display:”Line voltage”,press the

Left,Right button can switch and display other interface as following:Line

voltage \longleftrightarrow Current \longleftrightarrow Total power(power factor) \longleftrightarrow Time \longleftrightarrow maximum demand.

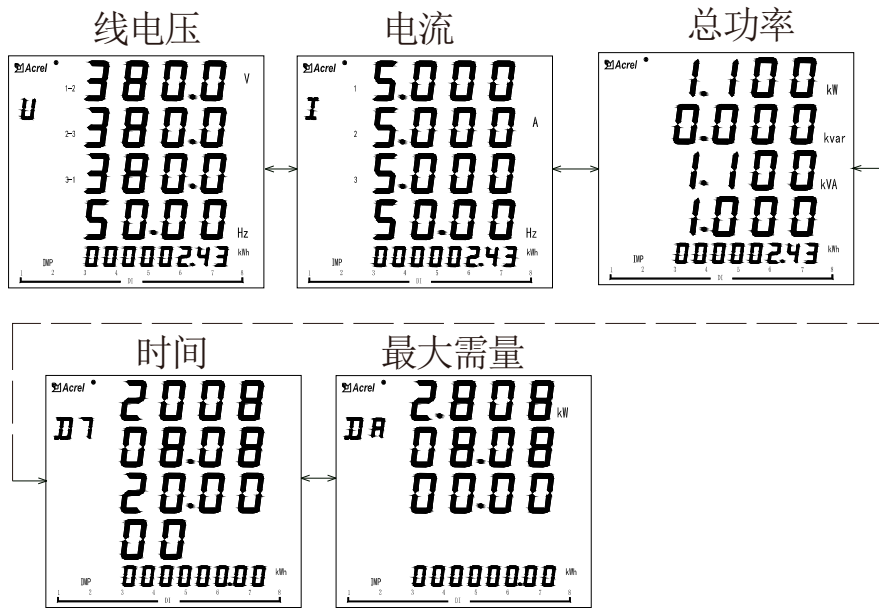

注：当带中性线电流时，电流界面如下（频率显示设为中性线电流显示）

The current interface is as follows (frequency display set as the neutral line current display)

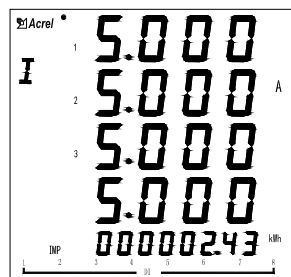

Note: in case there is the neutral line current, II 谐波参数 Harmonic parameter

仪表显示①相电压显示界面,按 SET 键切换到②电压总谐波含量界面后,按左、右键可切换显示其它界面:电压总谐波含量 \longleftrightarrow 电流总谐波含量 \longleftrightarrow 电压 2-63 次谐波含量(按左右键分别查看 2-63 次各次电压谐波含量) \longleftrightarrow 电流 2-63 次谐波含量(按左右键分别查看 2-63 次各次电流谐波含量) \longleftrightarrow 电压总谐波幅值 \longleftrightarrow 电流总谐波幅值 \longleftrightarrow 电压 2-63 次谐波幅值(按左右键分别查看 2-63 次各次电压谐波幅值) \longleftrightarrow 电流 2-63 次谐波幅值(按左右键分别查看 2-63 次各次电流谐波幅值)。

Meter display①Phase voltage displaying interface,press SET button,after switch to ② voltage Total Harmonic Content interface,press the Left,Right button can switch and display other interface as following: Voltage Total Harmonic Content \longleftrightarrow Current Total Harmonic Content \longleftrightarrow Voltage 2-63 order HarmonicContent(press the Left,Right button can look over Voltage 2-63 order Harmonic respectively) \longleftrightarrow Current2-63 order Harmonic Content(press the Left,Right button can look over Current 2-63 order Harmonic respectively) \longleftrightarrow Voltage Total Harmonic Amplitude \longleftrightarrow Current Total Harmonic

Amplitude←→Voltage 2-63 order Harmonic Amplitude
 Amplitude(press the Left,Right button can look over Voltage 2-63 order Harmonic Amplitude respectively)←→Current2-63 order Harmonic

Amplitude(press the Left ,Right button can look over Current 2-63 order Harmonic Amplitude respectively).

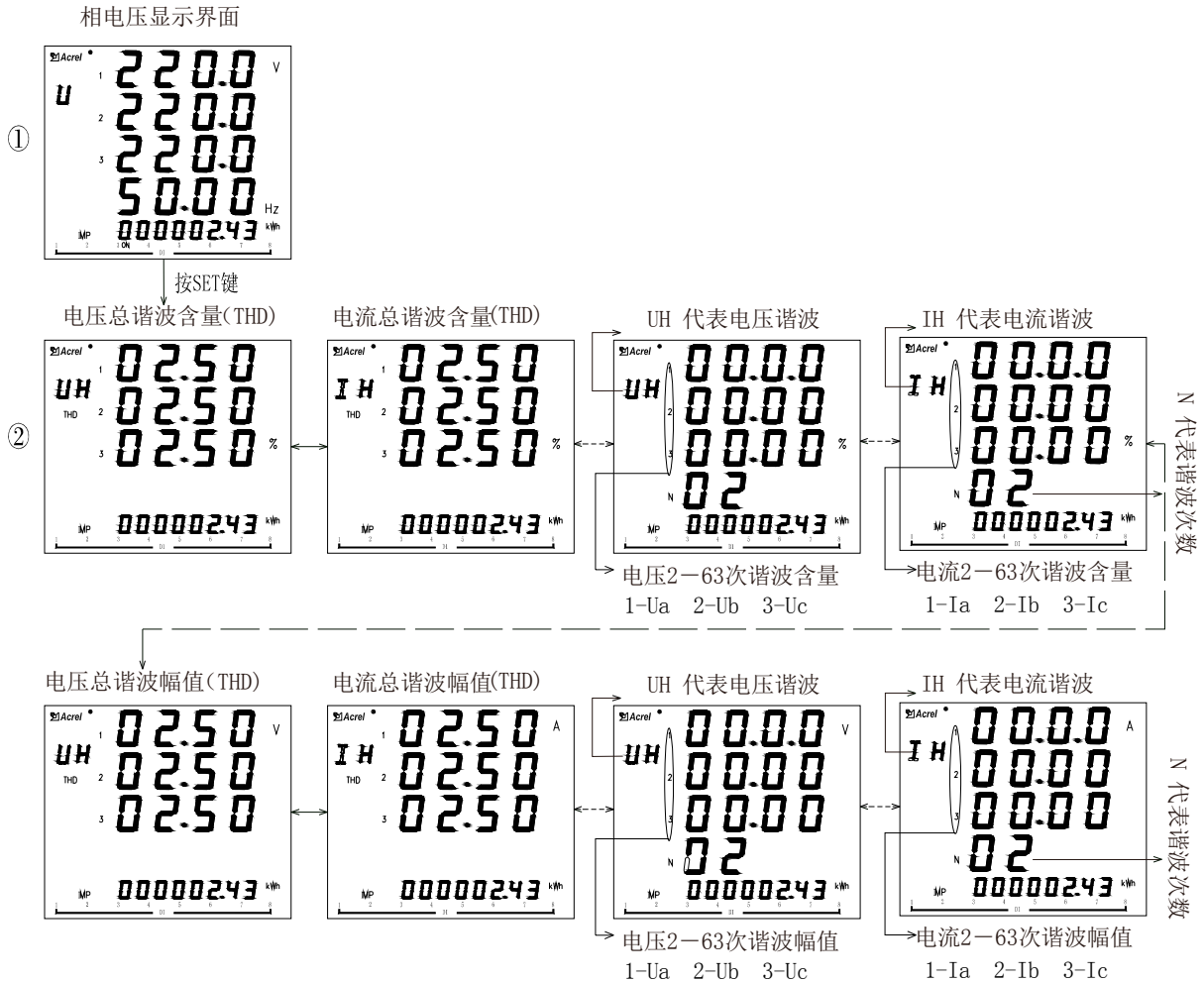

III费率电度 (电能显示为一次侧电能或二次侧电能, 可设置)

IIIKWH-rate(Electric energy display is Secondary side Electric energy)

仪表开机后显示①相电压显示界面时, 按 SET 键切换到③电流显示界面后, 按左右键切换显示:
 EIMP(总吸收有功电能) ←→ EEXP (总释放有功电

能) ←→ E $\text{---}\text{---}\text{---}$ (总感性无功电度) ←→
 $\text{---}\text{---}\text{---}$ E

(总容性无功电度) ←→ 本月 EIMP (F0) ←→ 本月 EIMP (F1) ←→ 本月 EIMP (F2) ←→ 本月 EIMP (F3) ←→ 本月 EIMP (F4) ←→ 上月 EIMP (F0) ←→ 上月 EIMP (F1) ←→ 上月 EIMP (F2) ←→ 上月 EIMP (F3) ←→ 上月 EIMP (F4) ←→ 上上月 EIMP (F0) ←→ 上上月 EIMP (F1) ←→ 上上月 EIMP (F2) ←→ 上上月 EIMP (F3) ←→ 上上月 EIMP (F4)。

After power up, meter display ① Phase voltage displaying interface, press SET button, after switch to ③ current/power display interface, press the Left, Right button can switch and display other interface as following: E_{IMP} (Total capture active electric energy) ←→ E_{EXP} (Total release active electric energy) ←→ E $\text{---}\text{---}\text{---}$ (Total inductive active electric energy) ←→ E $\text{---}\text{---}\text{---}$ (Total capacitive active electric energy) ←→ This month E_{IMP} (F0) ←→ This month E_{IMP} (F1) ←→ This month E_{IMP} (F2) ←→ This month E_{IMP} (F3) ←→ This month

$E_{IMP}(F4) \longleftrightarrow \text{Last month } E_{IMP}(F0) \longleftrightarrow \text{Last month } E_{IMP}(F1) \longleftrightarrow \text{Last month } E_{IMP}(F2) \longleftrightarrow \text{Last month } E_{IMP}(F3) \longleftrightarrow \text{Last month } E_{IMP}(F4) \longleftrightarrow \text{Month before last } E_{IMP}(F0) \longleftrightarrow \text{Month before last } E_{IMP}(F1) \longleftrightarrow \text{Month before last } E_{IMP}(F2) \longleftrightarrow \text{Month before last } E_{IMP}(F3) \longleftrightarrow \text{Month before last } E_{IMP}(F4)$.

注：1、四象限电能分别指吸收有功电能、释放有功电能、感性无功电能、容性无功电能，一般来说用户读取吸收有功电能 E_{IMP} ；复费率的电能计量分为 2 个时区，一时区为 8 个时段，二时区为 9 个时段（一时区可通过按键和通讯设置；二时区只能在通讯中设置，如出厂已设置为双时区，调整菜单设置费率只能修改一时区的内容，要修改为单时区需通讯设置），4 种费率（F0-有功尖峰电能，F1-有功峰电能，F2-有功平电能，F3-有功谷电能）来完成电能的分时计量。

2、F4 表示该月总的复费率有功电能。

3、抄表日为自然月，每月月底的 23:59:59 跳到次月 1 日 00:00:00 时自动会把当月有功电能 $E_{IMP}(F0-F4)$ 数值放入“上月有功 $E_{IMP}(F0-F4)$ ”显示界面中，上月有功电能 $E_{IMP}(F0-F4)$ 数值放入“上月有功 $E_{IMP}(F0-F4)$ ”显示界面中，同时“本月有功 $E_{IMP}(F0-F4)$ ”显示值清零。

Note:1. Four-quadrant electric energy refer to capture active electric energy, release active electric energy, inductive reactive electric energy, capacitive reactive electric energy respectively, generally, user read capture active electric energy E_{IMP} ; Multi-rate electric energy metering is divided into 2 time intervals; time interval I has 8 time periods and time interval II has 9 time periods (time interval I to be set via button and communication; time interval II only to be set in communication), such as factory settings has been set for two time zones, adjust the menu setting rate can only modify the contents of the first time zone, to change to a single time zone need to be set by communication). four rates (F0-active tip Electric energy, F1-active Peak Electric energy, F2-active Flat Electric energy, F3-active valley Electric energy) to accomplish sharing-time metering of electric energy.

2. F4 means Total multi-rate active Electric energy of this month.

3. Meter reading day adopt nature month, when jumping from 23:59:59 of this month to 00:00:00 of first day of next month, total multi-rate active electric energy of this month $E_{IMP}(F0-F4)$ is automatically put on “last month active electric energy $E_{IMP}(F0-F4)$ ” displaying interface, and last month active electric energy $E_{IMP}(F0-F4)$ is automatically put on “month before last active electric energy $E_{IMP}(F0-F4)$ ” displaying interface, while “Month active electric energy $E_{IMP}(F0-F4)$ ” is clearing its display value.

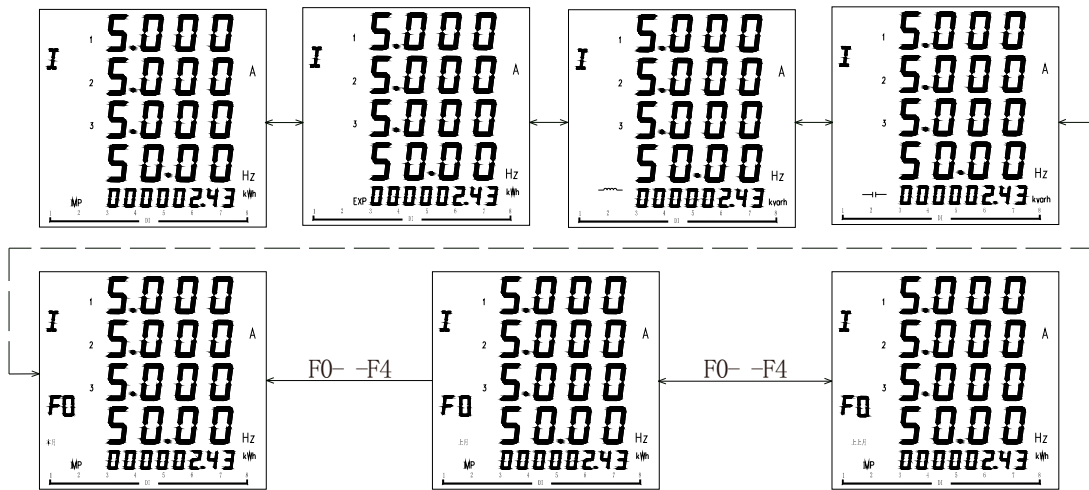

注：本月/上月/上上月 E(IMP)F0-尖，F1-峰，F2-平，F3-谷，F4-总（F1-F4 省略，按左右键即可显示）

NOTE: this month / last month / month before last E (IMP) F0- tip, F1- peak, F2- flat, F3- valley, F4- total (F1-F4 are omitted, press left/right button to display)

7.1.4 系统设置 System settings

I 编程菜单 Programming Menu

仪表开机后显示①相电压显示界面，按 SET 键切换到⑤PASS（输入密码“0001”）进入菜单编程界面，按左右键依次显示如下：

After power up, meter display ① Phase voltage displaying interface, after press SET to switch to ⑤ PASS (input password "0001") enter menu programming interface, press Left/Right button, the displaying sequence as following:

第一级菜单 First menu	第二级菜单 Second menu	说明 Description	
<i>In.Pt</i>	0~9999	电压倍数 Voltage transformation ratio	例：10KV/100V 即设为 0100 150A/5A 即设为 0030 Case: 10KV/100V set for 0100 150A/5A set for 0030
<i>In.Ct</i>	0~9999	电流倍数 Current transformation ratio	
<i>LinE</i>	3P3L、3P4L	接线方式（三相三线、三相四线） Connection mode(3-phase 3-wire;3-phase 4-wire)	
<i>In.U</i>	100、400、660	输入电压范围 Voltage grade	
<i>In.I</i>	1、5	输入电流范围 Current grade	
<i>Addr</i>	1~247	通讯地址 Communication address	
<i>bAUD</i>	1200、2400、4800、9600、19200、38400	通讯波特率 Communication Baud rate	
<i>SYS</i>	<i>CLr.E</i>	按回车键，电能清零 Press ENTER, Electric energy reset	
	<i>CLr.d</i>	按回车键，清除最大需量 Press ENTER to clear maximum demand	
	<i>CLr.S</i>	按回车键，清除事件记录 Press ENTER to clear events log	
	<i>CLr.n</i>	按回车键，清除极值 Press ENTER to clear polarity value	
	<i>CLr.T</i>	按回车键，清除系统运行时间 Press ENTER to clear system running time	
	<i>dS.EP</i>	选择显示一次侧电能还是二次侧电能 Select to display primary or secondary electric	
	<i>nodE¹</i>	第一路通讯校验 First-way communication calibration	
<i>bAUD²</i>	第二路通讯的通讯波特率 Second-way communication baud rate (1200、2400、4800、9600、19200、38400)		

	node²	第二路通讯校验 Second-way communication calibration
	645 Addr	645 规约的地址设置 645 Convention address set
Time	依次显示年、月、日、时、分、秒 Followed by the year, month, day, hour, minute, second	设置当前时间 Set current time
do.1-do.4	更多详细信息详见 (7.1.5) More details are given in (7.1.5)	
rt-1	3 ——— 0000 (可设 settable)	表示在 00:00—03:00 时间段中, 费率为 3—谷 Within 00:00—03:00 time period, rate as 2-Valley
rt-2	2 ——— 0300 (可设 settable)	表示在 03:00—06:00 时间段中, 费率为 2—平 Within 03:00—06:00 time period, rate as 2-Flat
rt-3	2 ——— 0600 (可设 settable)	表示在 06:00—09:00 时间段中, 费率为 2—平 Within 06:00—09:00 time period, rate as 2-Flat
rt-4	1 ——— 0900 (可设 settable)	表示在 09:00—12:00 时间段中, 费率为 1—峰 Within 09:00—12:00 time period, rate as 1-Peak
rt-5	0 ——— 1200 (可设 settable)	表示在 12:00—15:00 时间段中, 费率为 0—尖 Within 12:00—15:00 time period, rate as 0-Tip
rt-6	1 ——— 1500 (可设 settable)	表示在 15:00—18:00 时间段中, 费率为 1—峰 Within 15:00—18:00 time period, rate as 1-Peak
rt-7	2 ——— 1800 (可设 settable)	表示在 18:00—21:00 时间段中, 费率为 2—平 Within 18:00—21:00 time period, rate as 2-Flat
rt-8	2 ——— 2100 (可设 settable)	表示在 21:00—00:00 时间段中, 费率为 2—平 Within 21:00—00:00 time period, rate as 2-Flat
tr.1-tr.4	第一路到第四路为变送输出 (详见 7.1.6) First way to fourth way transmission output (details given in 7.1.6)	
b.Lcd	0 ——— 255 (可设 settable)	设置为 0 时, 背光常亮; 设置为 1-255 时, 背光在 1-255 秒后熄灭, 单位: 1 秒 Setting as 0, backlight lights; Setting as 1-255, after 1-255 Second backlight go out, Unit: 1 second

注：A:开关量输出:采用继电器输出，继电器触点有两种控制方式：1、电平方式（继电器触点常开或常闭）；2、脉冲方式（继电器闭合一段时间后断开，持续时间可调由“DO.1—DO.4”中的“DLY”控制）

B: 电能复费率计量:复费率的电能计量分为2个时区，一时区为8个时段，二时区为9个时段（一时区可通过按键和通讯设置；二时区只能在通讯中设置），四种费率来完成电能的分时计量，所有的操作都依据仪表内部 RTC 的时间实现，根据需求可通过仪表的编程设置8(9)种时段和四种不同的费率，或者通过仪表的 RS485 接口写入“rt.1----rt.8”的控制字（手动设置或通讯写入费率时段时必须要保证下一时段所设置的时间大于上一时段所设置的时间）。

7.1.5 开关量输出增加的菜单

ACR 谐波仪表开关量输出采用继电器输出，有两种控制方式：1、报警方式（“SEL”选择不为零）；2、总线控制方式（“SEL”选择为“0.do”，此时“dLy”设置为0为电平输出方式，设置非零为脉冲方式动作后延时设置的时间自动断开）

“SEL”中设置 DO 输出类型，“0.do”表示为通信控制（此时如果 DLY 设置为0输出为电平方式，否则为脉冲方式，如果 DLY 设置为2，吸合后0.02秒自动断开），其他为报警控制（见下表）

Note:A:Switching output:adopt relay output,relay contacts have two control modes:1.Level mode(relay contact adopt NO or NC);2.Pulse mode(relay is closed for some time then is breaking,the duration may be adjustable, controlled by 'DLY' of the 'DO.1-DO.4');

B:Electric energy multi-rate metering: multi-rate electric energy metering is divided into 2 time intervals; time interval I has 8 time periods and time interval II has 9 time periods (time interval I to be set via button and communication; time interval II only to be set in communication); time-based metering of electric energy is completed by four rates, all the operation are based on precise RTC time in the meter,the 8-time period,and adopt three rates can be set by meter programming key pad according to demand,or through meter RS485interface write in Control Word (Manually setting or communication write in rate-time period must guarantee that the setting time for next time period shall be greater than the setting time for last time period).

7.1.5 Added menu for switch volume output

ACR harmonic meter switch volume output adopts relay output; there are two control modes: 1. Alarm mode ("SEL" as zero); 2. Bus control mode ("SEL" as "0.do", and then "dLy" set as 0 level output mode; set as non-zero means auto disconnection of pulse mode post action delay time)

"SEL" set DO output type, "0.do" indicate communication control (and then in case DLY set as 0 output potential mode, or else pulse mode; in case DLY set as 2, auto disconnect in 0.02 seconds after closing), other alarm control (given in table below)

“dLy”为报警延时（报警用时推荐不设置为 0 防止干扰误动。）

"dLy" as alarm delay (alarm setting not recommended as 0 to prevent error action due to interference)

“bAnd”为不动作带设置

"bAnd" no action interval

“AL.Hi”为高报警数值设置（不用设置最大 9999）

"AL.Hi" high alarm value setting (no setting of maximum 9999)

“AL.Lo”为低报警数值设置（不用设置最小 -9999）

"AL.Lo" low alarm value setting (no setting of minimum -9999)

（以上 3 个设置与电量的显示值对应，显示中含小数点。例：输入 220V 100A/5A，三相四线，则 100%P 总为 220*100*3=66kW。如 100%功率时高报警，“AL.Hi”可取 66.00；100%电压时高报警，“AL.Hi”可取 220.0；100%电流时高报警，“AL.Hi”可取 100.0）

（three sets above correspond to electric energy readings and readings contain decimal point, e.g. input 220V 100A/5A, three phase four wire, 100%P total as 220*100*3=66kW, e.g. 100% power high alarm, "AL.Hi" taken as 66.00; 100% voltage high alarm, "AL.Hi" taken as 220.0; 100% current high alarm, "AL.Hi" taken as 100.0）

“In.=0”为信号为 0 时是否允许低报警，Lo.on 使能，Lo.of 禁止。

" In.=0" whether the low alarm is allowed when the signal is 0, Lo.on enabled, Lo.of disabled.

do.1	第一路继电器输出 First-way relay output							
	0	由通信控制的 DO 输出模式，此时“dLy”为 0 则为电平控制。设置其他值为自动返回模式。DO 动作后延时“dLy”（单位为 0.01 秒）后自动断开						
	do	Communication controlled DO output mode, "dLy" 0 means potential control; set as other value means auto return mode; auto disconnection after DO post action delay "dLy" (unit 0.01 second)						
	01	02	03	04	05	06	07	08
	U _A	U _B	U _C	相电压报警值 Phase voltage alarm value	U _{AB}	U _{BC}	U _{CA}	线电压报警值 Linear voltage alarm value
	09	10	11	12	13	14	15	16
	I _A	I _B	I _C	电流报警值 Current alarm value	P _A	P _B	P _C	P _总
	17	18	19	20	21	22	23	24
	Q _A	Q _B	Q _C	Q _总	S _A	S _B	S _C	S _总
	25	26	27	28	29	30	31	32
PF _A	PF _B	PF _C	PF	F	电压不平衡 Voltage unbalance	电流不平衡 Current unbalance	中性线电流 Neutral line current	
SEL								

dLy	输出延时时间 Output delay time 如果为 DO 输出方式, 设置为 0 时, 为电平控制方式, 非 0 时为脉冲控制方式, 延时设置的时间后断开, 延时设置范围 1—255 时, 单位: 0.01 秒; In case of DO output mode, set as 0, potential control mode; set as non 0 pulse control mode, disconnection after delay set time, delay set scope 1-255, unit: 0.01 second; 如果为报警输出方式, 延时设置范围 1—9999 时, 单位: 1 秒; In case of alarm output mode, delay set scope 1—9999, unit: 1 second;
bAnd	不动作带区间 No action interval
ALH	高报警值 范围-9999~9999 (忽略小数点位置) Scope of high alarm value -9999~9999 (decimal point not considered)
	低报警值 范围-9999~9999 (忽略小数点位置) Scope of low alarm value -9999~9999 (decimal point not considered)
ALLo	Lo.on 信号为 0 时可触发低报警 Lo.on signal 0, low alarm may be triggered
In=0	Lo.oF 信号为 0 时不触发低报警 Lo.oF signal 0, low alarm is not triggered

注: 1. 三相 XX 最大值表示: 高报警时为三相中最大值, 低报警时为三相中最小值。

2. 第 2 路 DO 可设置“33.FL”组合报警功能, 设置后二级菜单变为“SEL”(功能选择)、“dLy”(延时)、“H- U”(过线电压)、“L- U”(欠线电压)、“H- F”(过频率)、“L- F”(欠频率)、“H- P”(过功率)、“L- P”(欠功率)、“H- I”(过电流)、“L-PF”(欠功率因数)、“H-b.U”(过电压不平衡, 设置为-1 断相, 判定条件至少一相 $>0.5U_e$, 至少一相 $<0.1U_e$)、“H-b.I”(过电流不平衡, 设置为-1 断相, 判定条件至少一相 $>0.2I_e$, 至少一相 $<0.01I_e$)

3. 不平衡计算

(偏移平均值最大的值与平均值的差值)/平均值*100%, 如果分母的平均值小于额定值, 分母为额定值。电压额定值 U_e : 3 相 4 线 U_e 为相电压, 菜单中设置的 400V 的仪表为 $220V*PT$, 100V 的仪表为 $57V*PT$ 。电流额定值 I_e : 5A 的仪表为 $5A*CT$, 1A 的仪表为 $1A*CT$ 。

不平衡度下设置的参数为百分比格式, 如设置为 20 表示 20%。

Note: 1. Indication of three phase XX maximum/minimum value: high alarm represents maximum value of three phase; low alarm represents minimum value of three phase

2. Second way DO to be set as "33.FL" combination alarm function; after setting, level II menu changed as "SEL" (function selection), "dLy" (delay), "H-U" (high voltage), "L-U" (low voltage), "H-F" (high frequency), "L-F" (low frequency), "H-P" (high frequency), "L-P" (low power factor), "H-b.U" (over voltage unbalance, set as -1 phase miss, judgement condition at least one phase $>0.5U_e$, at least one phase $<0.1U_e$), "H-b.I" (over current unbalance, set as -1 phase miss, judgement condition at least one phase $>0.2I_e$, at least one phase $<0.01I_e$)

3. Unbalance calculation

(Difference between maximum deviation from the mean value and mean value)/mean value *100%, if the mean value of denominator is less than the rated value, the denominator is rated value; voltage rated value U_e ; 3 phase 4 wire U_e as the phase voltage, menu setting 400V instrument as $220V*PT$, 100V instrument as $57V*PT$. Current rated value I_e : 5A instrument as $5A*CT$, 1A instrument as $1A*CT$.

Unbalance set parameter in percentage, e.g.

20 means 20%

7.1.6 如何修改变送设置

模拟变送输出可选择将电网中常见的 27 个电量(U_A 、 U_B 、 U_C 、 U_{AB} 、 U_{BC} 、 U_{CA} 、 I_A 、 I_B 、 I_C 、 P_A 、 P_B 、 P_C 、 $P_{总}$ 、 Q_A 、 Q_B 、 Q_C 、 $Q_{总}$ 、 PF_A 、 PF_B 、 PF_C 、 $PF_{总}$ 、 S_A 、 S_B 、 S_C 、 $S_{总}$ 、 F 、 I_N) 隔离变送输出为 0-20mA 或 4-20mA 的直流信号。

Analog transmission output may opt to select

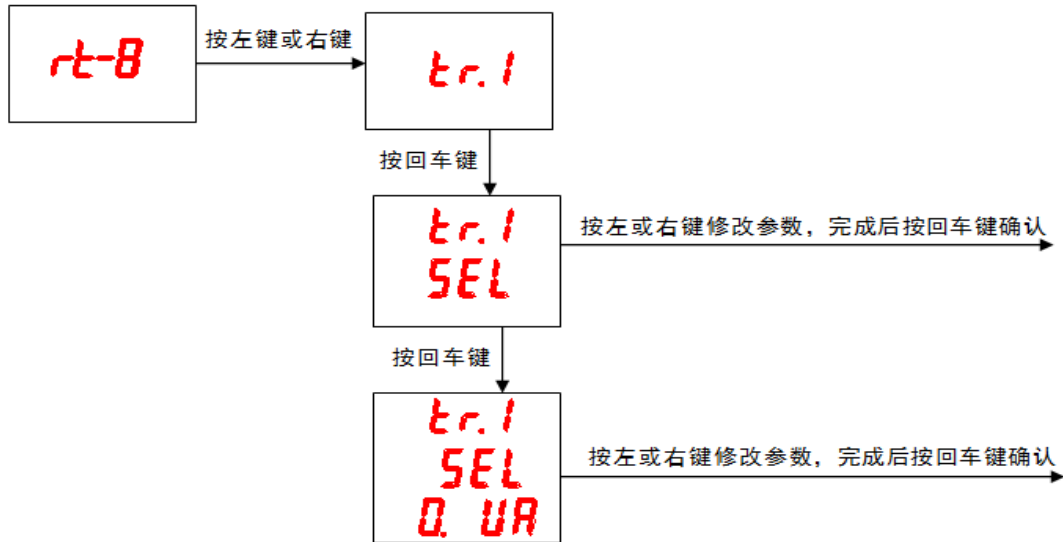

7.1.6 How to change transmission setting

27 common electric energy readings in the power grid (U_A , U_B , U_C , U_{AB} , U_{BC} , U_{CA} , I_A , I_B , I_C , P_A , P_B , P_C , P_{total} , Q_A , Q_B , Q_C , Q_{total} , PF_A , PF_B , PF_C , PF_{total} , S_A , S_B , S_C , S_{total} , F , I_N) as 0-40mA or 4-20mA direct current signal for isolation transmission output.

tr. 1	第一路变送 First-way transmission								
	00	01	02	03	04	05	06	07	
SEL	U_A	U_B	U_C	U_{AB}	U_{BC}	U_{CA}	I_A	I_B	
	08	09	10	11	12	13	14	15	
	I_C	P_A	P_B	P_C	P_{total}	Q_A	Q_B	Q_C	
	16	17	18	19	20	21	22	23	
	Q_{total}	S_A	S_B	S_C	S_{total}	PF_A	PF_B	PF_C	
	24	25	26						
	PF	F	I_N						
TYPE	4~20mA 或 0~20mA 4~20mA or 0~20mA								
Rd.H,	20mA 输出与电量的显示值相对应：如输入为 220V，100A/5A，三相四线制，则 100%P 总为 $220V \times 100A \times 3 = 66kW$ ，显示值为 66.00kW，则该值取 66.00(计小数点)，若三相三线，则 $220kV \times 100A \times \sqrt{3} = 38.10kW$ ；该值取 38.10，其它电量模拟量输出设置类似。 20mA output corresponding to electric energy reading: in case of input 220V, 100A/5A, three phase four wire, 100%P means $220V \times 100A \times 3 = 66kW$, reading 66.00kW, the value is taken as 66.00 (decimal points considered); in case of three phase three wire,								

	220kV×100A×√3=38.10kW; if the value is taken as 38.10, other electric energy analog output set is similar.								
RoLo	变送低点对应值 Value corresponding to transmission low point								
tr.1	第一路变送 First-way transmission								
SEL	00	01	02	03	04	05	06	07	
	U _A	U _B	U _C	U _{AB}	U _{BC}	U _{CA}	I _A	I _B	
	08	09	10	11	12	13	14	15	
	I _C	P _A	P _B	P _C	P _总	Q _A	Q _B	Q _C	
	16	17	18	19	20	21	22	23	
	Q _总	SA	SB	SC	S _总	PF _A	PF _B	PF _C	
	24	25	26						
	PF	F	I _N						
TYPE	4~20mA 或 0~20mA								
RoH,	20mA 输出与电量的显示值相对应：如输入为 220V，100A/5A，三相四线制，则 100%P 总为 220V×100A×3=66kW，显示值为 66.00kW，则该值取 66.00(计小数点)，若三相三线，则 220kV×100A×√3=38.10kW；该值取 38.10，其它电量模拟量输出设置类似。 20mA output corresponding to electric energy reading: in case of input 220V, 100A/5A, three phase four wire, 100%P means 220V×100A×3=66kW, reading 66.00kW, the value is taken as 66.00 (decimal points considered); in case of three phase three wire, 220kV×100A×√3=38.10kW; if the value is taken as 38.10, other electric energy analog output set is similar.								
RoLo	变送低点对应值 Value corresponding to transmission low point								

II 系统设置流程图 (末页附图)

System setting flow chart (attached drawing at the last page)

系统设置图

- 注：1、“SET”表示仪表左起第一个按键，“←”表示第二个按键，“→”表示第三个按键，“↵”表示第四个按键。途中无特殊说明“↔”表示单击左键或者单击右键，“↑”表示单击“SET”键返回，“↓”表示单击“↵”确认。
- 2、图中“A/B/C (如0000尖/0001峰/0002平/0003谷)”表示可选择，“xxxx”表示可进行数值设置。在选择或数值设置完成后，单击“↵”保存，如不欲保存，单击“SET”见退出当前菜单。
- 3、在所有的实质完成后，单击“SET”键直到出现“SAVE/YES”，如要保存单击“↵”键；如不需保存，单击“SET”键返回正常工作状态。
- 4、要特别谨慎电能清零项的设置，一旦清零数值将不能恢复。

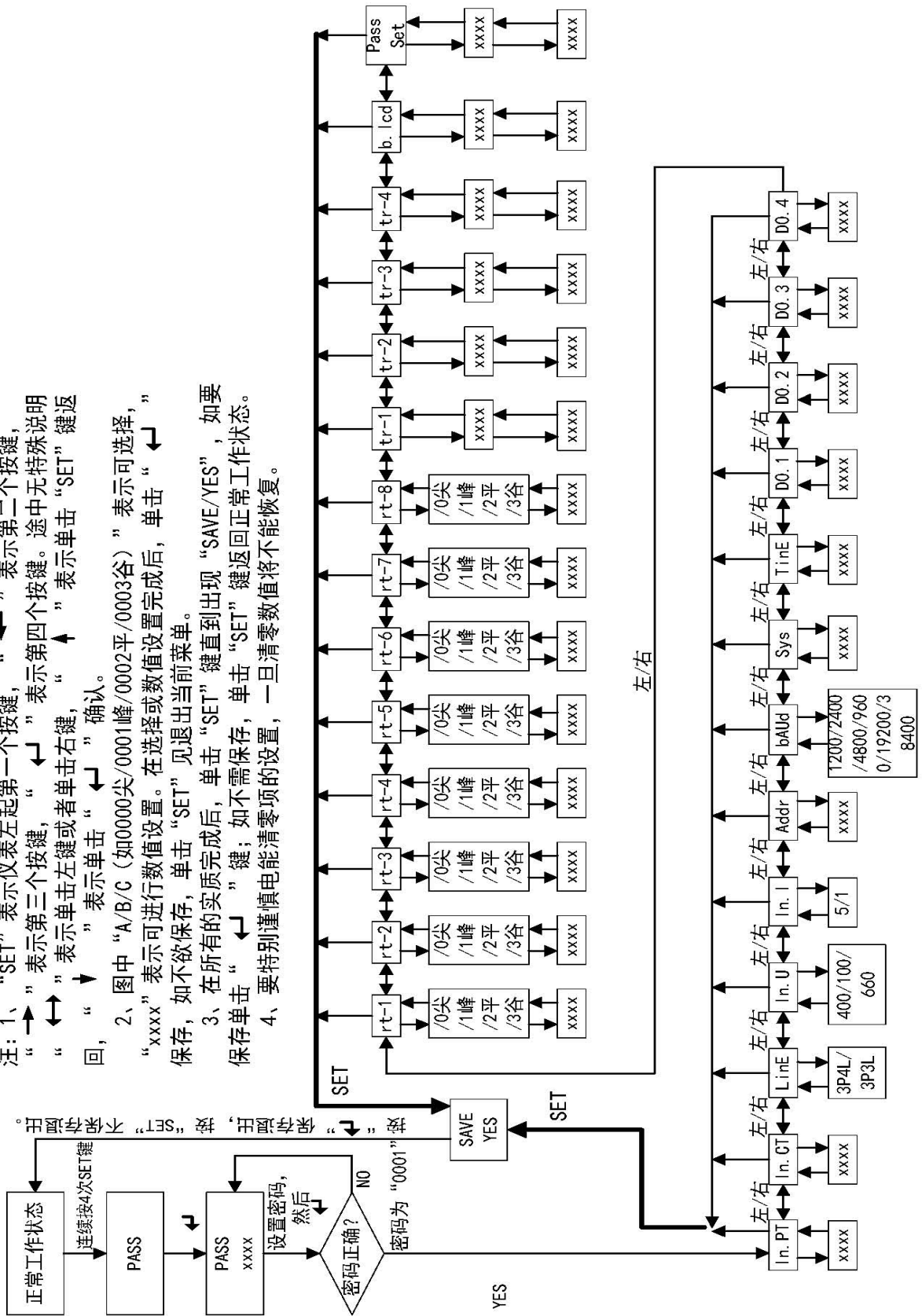

7.2 ACR230ELH/ACR330ELH 操作指南 Operation guide

7.2.1 主菜单 Main menu

仪表接通电源后,瞬间显示界面为软件版本号,之后屏幕即刻显示为相电压界面,此时按 SET 键可进入主菜单界面。进入主菜单后,可按上键或下键选择所需查看的项目,当所需查看的项目处于反白状态时按回车键进入该项目。

After power on,the first display interface is the software version number,then display Phase voltage interface at once,at this time,press SET key can enter Main menu.After enter Main menu ,press the Up/Down button to select the item to looking over,when this item is in Anti-whitestatus,to press Enter key entering this item.

主菜单	
电力参数	事件记录
谐波参数	极值记录
电网质量	开关状态
费率电度	用户设置

Main menu	
Electric parameters	Event log
Harmonic parameters	Extremum log
Power grid quality	Switch states
Rates for electricity	User settings

7.2.2 电力参数 Power parameter

A: 对三相四线系统,仪表上电(或选中电力参数后按回车键)显示如下图所示 01 界面(相电压),按上、下键可切换显示其它界面:相电压←→线电压←→电流←→有功功率←→无功功率←→视在功率←→总功率→功率因数←→最大需量。

注: 只有在有功功率的情况下才会有最大需量

A:For three-phase four-wire system,meter is power on (or select Power parameter and press Enter key),displaying below diagram 01 interface (Phase voltage),pressing the Up/Down button to switch,to display other interface:Phase voltage←→Linevoltage←→current←→Active power←→Reactive power←→Apparent Energy←→Total power ←→powerfactor ←→maximum demand

Note:Only in active condition ,the maximum demand may occur.

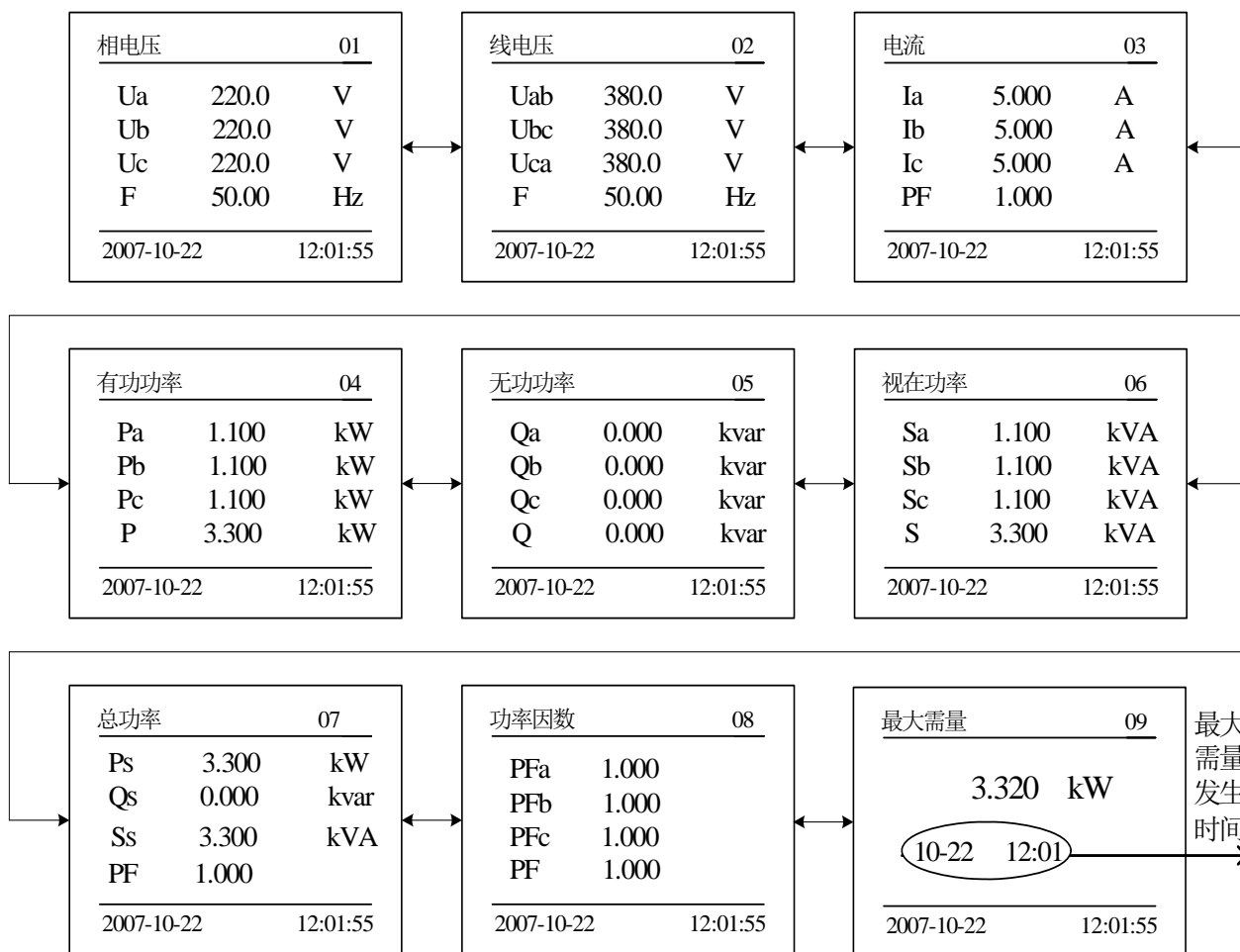

注：相电压界面按 ENTER 键进入电压角度界面，电流界面按 ENTER 键进入电流角度界面。

Note: Press the ENTER key to enter the voltage angle interface in phase voltage interface, press the ENTER key to enter the current angle interface in phase current interface.

B: 对三相三线系统，仪表上电（或选中电力参数后按回车键）显示如下图所示 01 界面（线电压），按上、下键可切换显示其它界面：线电压 ↔ 电流 ↔ 总功率。

B: For three-phase three-wire system, meter is power on (or select Power parameter and press Enter key), displaying below diagram 01 interface (Line voltage), pressing the Up/Down button to switch, to display other interface: Line voltage ↔ current ↔ Total power.

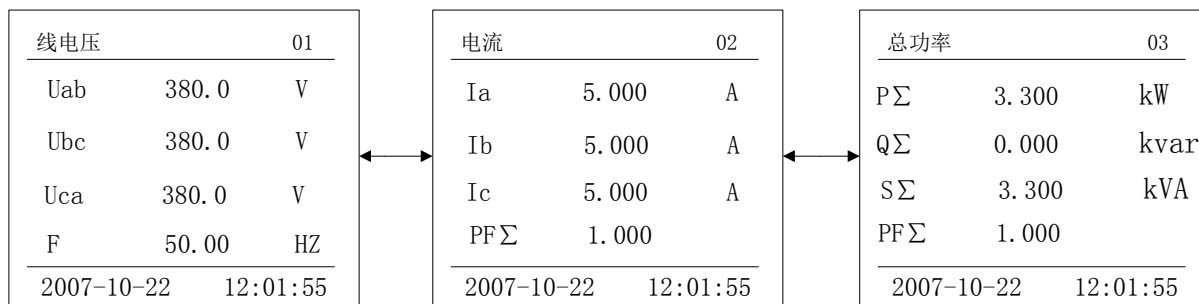

line voltage ↔ current ↔ total power

7.2.3 谐波参数 Harmonic parameter

仪表在选中谐波参数后按回车键进入谐波参数界面，此时谐波数据处于反白状态，按回车键查看电压电流谐波数据。

谐波数据处于反白状态时，按回车键进入谐波数据界面，该界面显示 2-7 次电压谐波，按上键或下键可切换显示其他次数电压和电流谐波数据和总谐波 THD,最高可测量到 31 次谐波。

注：谐波数据【(分次谐波幅值/基波幅值)×100%为百分比含量】

After selecting Harmonic parameter, press Enter key entering Harmonic parameter interface, when Enter key to look over voltage current harmonic data.

When harmonic data is in whitening status, press Enter key entering Harmonic data interface ,this interface display 2-7 order voltage harmonic, press the Up/Down button to switch display to other order voltage and current harmonic data and harmonic THD, the maximum measuring order is the 31 order harmonic.

Note: the harmonic data “(Sub-harmonic amplitude/Amplitude of the Fundamental Wave)×100%=percentage content” .

谐波参数
谐波数据
谐波棒图
谐波波形

Harmonic parameters
Harmonic data
Harmonic bar chart
Harmonic wave form

谐波数据处于反白状态时，按上键或下键选择谐波棒图，然后按回车键进入谐波棒图界面，该界面显示 A 相电压和电流的谐波棒图，按上键或下键可切换显示 B、C 两相的谐波棒图。

注：棒图显示最高显示到 21 次。

When harmonic data is in whitening status, press the Up/Down button to select harmonic bar graph, then press enter button to enter interface display harmonic bar graph. This interface indicates harmonic bar graph of A Phase voltage and current , press the Up/Down button can switch display harmonic bar graph of B,C two phase.

Note:The highest bar graph display is up to 21 order.

谐波数据处于反白状态时，按上键或下键选择谐波波形，然后按回车键进入谐波波形界面，该界面显示 A 相电压和电流的波形，按上键或下键可切换显示 B 相电压和电流的波形、C 相电压和电流的波形、三相电压波形和三相电流波形。

注：该项目可用于检查接线是否正确以及当前电网中的电压电流的实际情况。

When harmonic data is in whitening status.press the up/down button to select harmonic waveform, then press Enter key enter to harmonic waveform interface, this interface display waveform of A Phase voltage and current, press the Up/Down button can switch to display waveform of B Phase voltage and current, waveform of C Phase voltage and current, three

Phase voltage waveform and three Phase current waveform.

connection and actual electric network voltage /current status.

Note:Using this item can check in correct

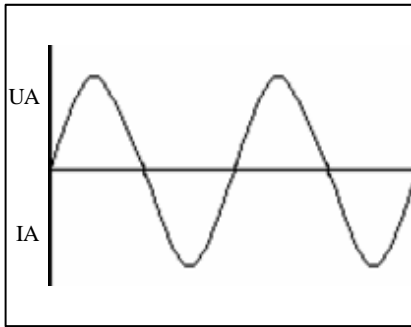

谐波波形
Harmonic wave

%	Ua	Ub	Uc
02	00.00	00.00	00.00
03	00.00	00.00	00.00
04	00.00	00.00	00.00
05	00.00	00.00	00.00
06	00.00	00.00	00.00
07	00.00	00.00	00.00

谐波数据
Harmonic data

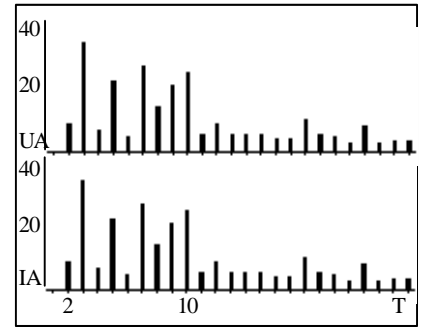

谐波棒图
Harmonic bar graph

7.2.4 电网质量 Power quality

注 1: ACR330ELH 仪表在主菜单中选中电网质量后按回车键进入电网质量界面,此时波峰系数处于选中状态,可按上下键选择要查看的内容,接着按回车键即可查看相应的电网质量参数。ACR230ELH 仪表在选中电网质量后按回车键进入波峰系数界面,按上下键即可查看其它的电网质量参数.(如下图)

Note 1:After selecting electric network quality in ACR330ELH main menu,press Enter key to enter electric network quality interface, then crest factor is selected,press up and down keys to select the content you want to view, then press the Enter key to see the corresponding power quality parameters. After selecting electric network quality in ACR230ELH main menu,press Enter key entering Wave peak coefficient interface,Press up and down keys to look over other Electric network quality parameter.(as below diagram).

电网质量	
波峰系数	峰值电压
电话波形因子	电压矢量
电流K系数	电流矢量
不平衡度	

Power grid quality	
Crest factor	Crest voltage
Telephone waveform factor	Voltage vector
Current K Factor	Current vector
Unbalance factor	

注 2: Note 2:

V_{pc}——正序电压 Positive-sequence voltage V_{nc}——负序电压 Negative-sequence voltage

V3u0——零序电压 Zero-sequence voltage

Cpc——正序电流 Positive-sequence current

Cnc——负序电流 Negative-sequence current

C3I0——零序电流 Zero-sequence current

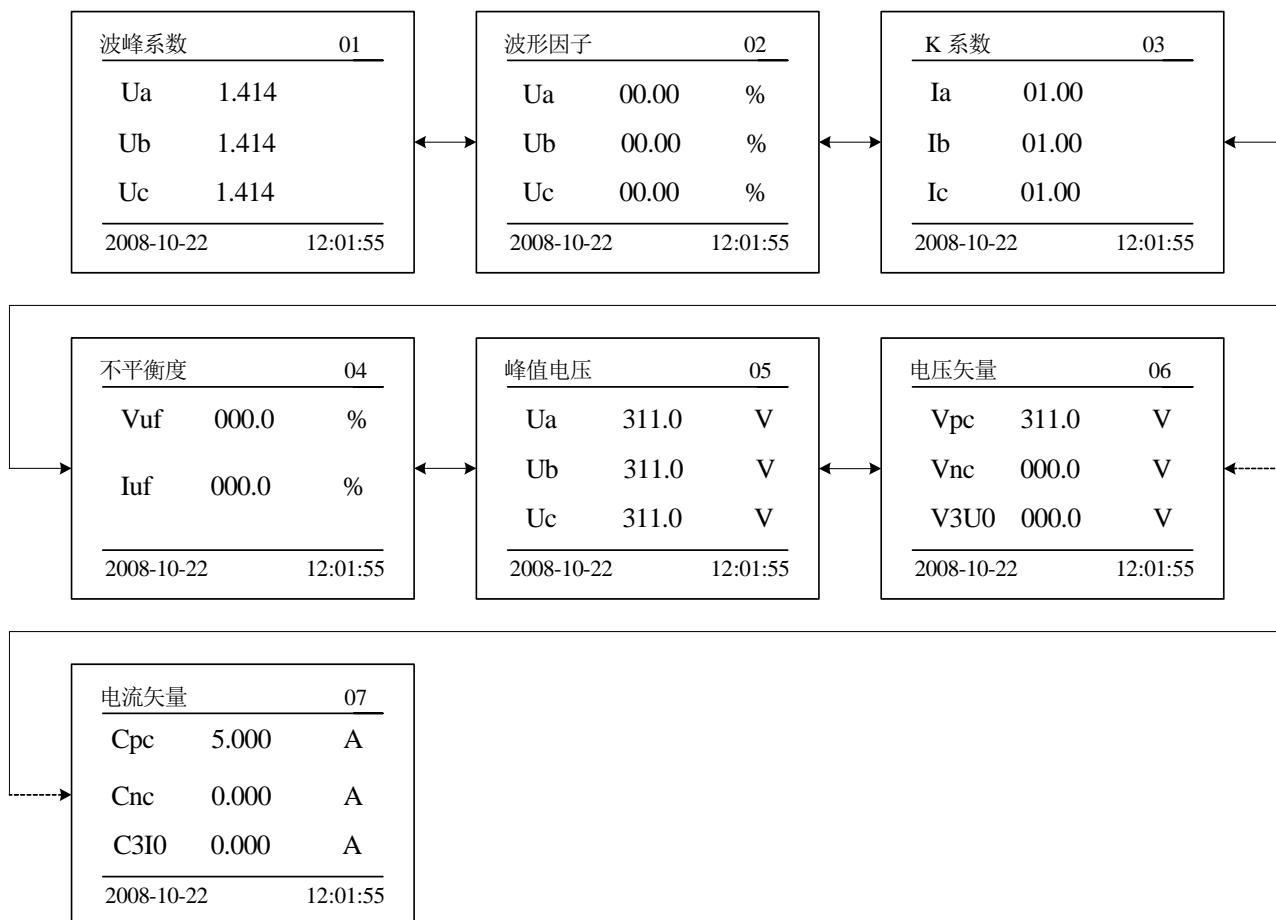

Crest factor——Waveform Factor——K Factor ——

Unbalance factor —— Crest voltage ——Voltage vector ——

Current vector

7.2.5 费率电度 KWH-rate

仪表在选中费率电度后按回车键显示本月复费率电能,此时按上键或下键切换显示上月、上上月、总的复费率电能以及四象限电能。

After selecting the KWH-rate and press Enter button to display the month of multi-rate power, then press the up or down keys to switch the display last month, month before last month, the total multi-rate power and four-quadrant power.

注 1: 该系列仪表电能显示为二次侧电能、一次侧电能可选, 四象限电能分别指吸收有功电能、释放有功电能、感性无功电能、容性无功电能。

Note 1:The electric energy display in this meter is the secondary side electric energy, the four-quadrant electric energy refer to capture active electric energy ,release active electric energy, inductive reactive electric energy, capacitive reactive electric energy respectively.

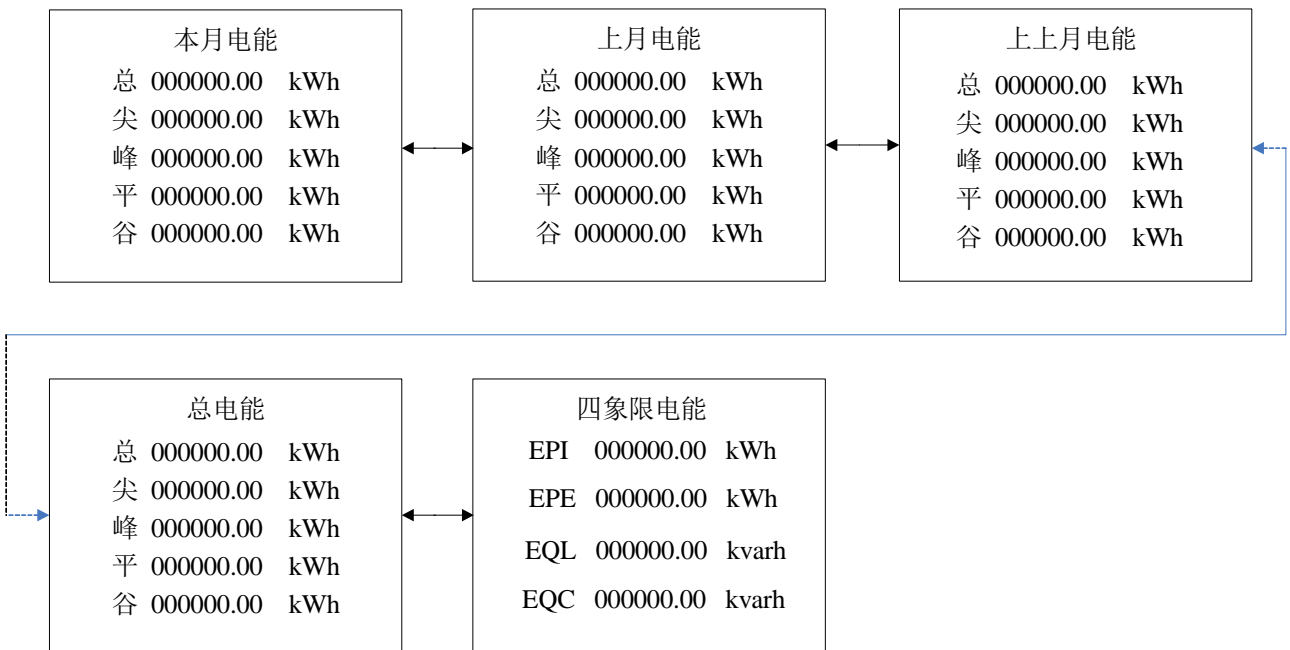

The electric energy of this month —— The electric energy of the last month —— The electric energy of the last two months —— Total electric energy —— The four-quadrant electric energy
 总 Total 尖 Summit 峰 Peak 平 Normal 谷 Valley

7.2.6 SOE 事件记录 Event record

仪表在选中事件记录后按回车键显示开关量输入输出的动作信息。如下图 (ACR330ELH) 所示第 1 条记录表示 08 年 11 月 1 日 11:01:45 时第 1 路开关量输入分; 第 2 条记录表示 08 年 11 月 1 日 10:31:40 时第 1 路开关量输入合; 第 3 条记录表示 08 年 11 月 1 日 10:01:45 时第 3 路继电器报警 (失压报警 失压故障时电压为 25.3V); 按上下键可查看其它记录, 共保存 16 条记录。

ACR230ELH 与之类似, “ON”和“OFF”相应表示开关量开和关。

After selecting Event record, press Enter key to display operation information of Switching input/output. As below diagram (ACR330ELH) shown, the first record in right figure show: At 01/11/2008.11:01:45, the First channel Switch input is OFF; the second record in right figure show: At 01/11/2008, 10:31:40, the First channel Switch input is ON; The third record in right figure show: At 01/11/2008, 10:01:45, the Third channel relay is alarming (No voltage alarm, for no voltage fault, the voltage is 25.3 V); press Up/Down button can look over other record, 16 of total records can be saved.

ACR230ELH is similar, 'ON' and 'OFF' is for switching ON and OFF respectively.

01	DI1	2008-11-01
	ON	11:01:45
02	DI2	2008-11-01
	ON	10:31:40
03	DI1	2008-11-01
	OFF	10:01:45

ACR230ELH

01	2008-11-01	DI1	
DI	11:01:45	分	
02	2008-11-01	DI1	
DI	10:31:40	合	
03	2008-11-01	D03	v
D0	10:01:45	025.3V	

ACR330ELH

7.2.7 极值记录 Fault oscillogram(Description on request of user)

仪表在选中极值记录后按回车键显示极值界面。如下左图表示 15 年 9 月 17 日 9: 49: 54 时 A/B/C 相电压最大值为 181.4V; 下右图表示 15 年 9 月 17 日 9:49:54 时 A/B/C 相有功功率最小值为 6.551kW。按上下键可查看其他参数的极值 (电压 U、电流 I、功率 P/Q/S、功率因数 PF、谐波 THD、频率 F 等)。

After selecting switch state, press the Enter key to display the switch status display. Switching status display the current relation of digital inputs and relay outputs real-time status, switch input power supported with + 5V power in the meter, the switch output is a passive relay contacts. When digital input or output, the corresponding indicator bit is from open to close.

MAX	Ua	181.4 V	2015-09-17 09:49:54	MIN	Pa	6.551 kW	2015-09-17 09:49:54
	Ub	181.4 V	2015-09-17 09:49:54		Pb	6.551 kW	2015-09-17 09:49:54
	Uc	181.4 V	2015-09-17 09:49:54		Pc	6.551 kW	2015-09-17 09:49:54

7.2.8 开关状态 Switch status

仪表在选中开关状态后按回车键显示开关量状态显示界面。开关状态显示当前相关的开关量输入与继电器输出实时状态。当有开关量输入或输出时, 相应的指示位由分变为合。

After selecting switch state, press the Enter key to display the switch status display. Switching status display the current relation of digital inputs and relay outputs real-time status. When digital input or output, the corresponding indicator bit is from open to close.

开关状态	
DI1=分	DO1=分
DI2=分	DO2=分
DI3=分	
DI4=分	

D01 分	D02 分	D03 分	
DI1 分	DI2 分	DI3 分	DI4 分

ACR230ELH

ACR330ELH

开关状态: Switch states

分: OFF

合: ON

7.2.9 用户设置 User settings

进入主菜单后, 按上键或下键选择用户设置项, 按回车键出现密码输入项, 此时按上键或下键可使光标在个、十、百、千位上移动, 当该位处于反白状态时, 可按左右键对该位数字增减, 密码 (默认为 0001) 输入正确后按回车键进入用户设置界面。

After entering main menu, press the Up/Down button to select user set up item, press Enter key to appear password input item, then press the Up/Down button to move cursor onto ones place, tens place, hundreds place, thousands place, when this bit is in whitening status, press the Left/Right button to increase/decrease number, after input correct password(default as 0001)press Enter key to enter user setting interface.

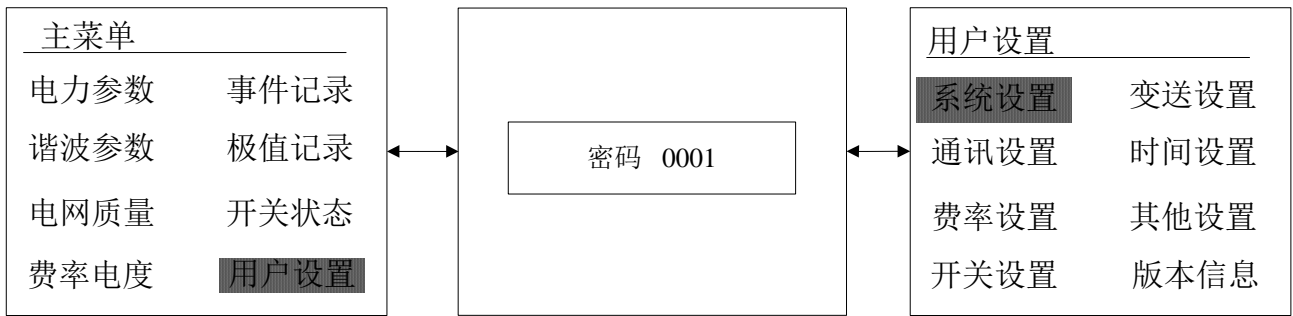

Main menu	
Electric parameters	Event log
Harmonic parameters	Extremum log
Power grid quality	Switch states
Rates for electricity	User settings

Password: 0001

User settings	
System settings	Transmitter settings
Communication setting	Time settings
Rates settings	Other settings
Switch settings	Version information

a) 系统设置:

进入用户设置界面后,按上下键选择系统设置,然后按回车键进入系统设置界面。在系统设置界面下按上下键选需要改变的项,使之处于反白状态,按左右键选择接线方式(三相四线、三相三线、单相)、电压等级(100V、400V、660V)、电流等级(5A、1A)或更改电压变比和电流变比。

a) System Settings:

After entering user setting interface, press the Up/Down button to select system setting, then press Enter key to enter system setting interface, Under system setting interface, press the Up/Down button to select item to be changed, and enable it in whitening status. Under whitening status, press the Left/Right button to select connection mode (3-phase 4-wire,3-phase 3-wire, Single phase), voltage grade (380v, 100v),current grade (5A,1A)or change voltage transformation ratio and current transformation ratio.

系统 设置	接线方式	三相四线
	电压等级	380V
	电流等级	5A
	电压变比	0001
	电流变比	0001
	密码设置	0001

System settings	Wiring method	three-phase four-way
	Voltage level	380V
	Current level	5A
	Voltage transformation ratio	0001
	Current transformation ratio	0001
	Password settings	0001

b)通讯设置:

进入用户设置界面后,按上下键选择通讯设置,按回车键进入通讯设置界面。在通讯设置界面下按上下键选需要改变的项,使之处于反白状态,按左右键改变通讯地址(1~247)、通讯波特率(1200bps、2400bps、4800bps、9600bps、19200bps、38400bps)、校验方式(无校验、奇校验、偶校验、2bits)、645规约地址。

b)communication settings:

After entering user setting interface, press the Up/Down button to select communication setting, then press Enter key to enter communication setting interface,Under communication setting interface, press the Up/Down button to select item to be changed, enable it in whitening status.Under whitening status,press the Left/Right button to change communication address(1~247) and to select communication baud rate (1200bps,2400bps,4800bps,9600bps,19200bps, 38400bps) and

通讯 设置	通讯地址	001
	波特率	9600
	校验方式	无校验位
	645规约地址	
		000000000000

Communication settings	Communication address	001
	Baud rate	9600
	Parity mode	no parity
	645 protocol address	
		000000000000

c)费率设置:

进入用户设置界面后,按上下键选择费率设置,并按回车键进入费率设置界面。在费率设置界面下,按上下键选择欲设置项,按左右键修改设置项值。仪表可设置8个时段和9时段、四种费率。按左右键修改设置项值。如下表所示:

注:设置费率时间时后面的时间一定要比前面的大,否则会出错。

c)Rate setting

After entering user set up interface,press the Up/Down button to select rate setting,then press Enter key to enter rate setting interface .After entering rate setting interface,press the Up/Down button to select item to be set,press the Left/Right button to revise item setting value.This meter can set 8 or 9 time periods,four kinds of rates,shown as below table:

Note:Manually setting rate-time period must guarantee that the setting time for next time period shall be greater than the setting time for last time period,if not,error may occur.

序号 No.	时间 Time	描述 Description
1	00: 00	在00: 00~06: 00 时间段中, 费率为平 Within 00: 00~06: 00 period of time ,rate is Flat
2	06: 00	在06: 00~08: 00 时间段中, 费率为平 Within 06: 00~08: 00 period of time ,rate is Flat
3	08: 00	在08: 00~10: 00 时间段中, 费率为平 Within 08: 00~10: 00 period of time ,rate is Flat
4	10: 00	在10: 00~12: 00 时间段中, 费率为峰 Within 10: 00~12: 00 period of time ,rate is Peak
5	12: 00	在12: 00~14: 00 时间段中, 费率为峰 Within 12: 00~14: 00 period of time ,rate is Peak
6	14: 00	在14: 00~16: 00 时间段中, 费率为平 Within 14: 00~16: 00 period of time ,rate is Flat
7	16: 00	在16: 00~22: 00 时间段中, 费率为平 Within 16: 00~22: 00 period of time ,rate is Flat
8	22: 00	在22: 00~00: 00 时间段中, 费率为平 Within 22: 00~00: 00 period of time ,rate is Flat

费率设置	
时区1	1 平 00:00 6 平 14: 00
时区2	2 谷 06:00 7 平 16: 00
月份时区选择	3 平 08:00 8 尖 22: 00
	4 峰 10:00
	5 峰 12:00

Rates settings
Time zone 1
Time zone 2
Month and time zone selection

Rates settings:	
1 Normal	6 Normal
2 Valley	7Normal
3 Normal	8 Peak
4 Summit	
5Summit	

d)开关设置: (默认为电平方式)

进入用户设置界面后, 按上下键选择开关(D01-DO4)设置, 按回车键进入开关设置界面。类型 DO 为通讯控制, 其余类型为报警控制(见下表)。只有开关 DO2 可选择组合报警类型 FL。

d)Switch setting:(Default is level mode)

After entering user setting interface, press the Up/Down button to select switch(DO1-DO4) setting, then press Enter key to enter switch setting interface .press the Up/Down button to select pre-set item(D01/D02),press the Left/Right button to revise trigger mode(electrical level/pulse),under pulse mode, setting pulse triggering delay is possible.

01	02	03	04	05	06	07	08
UA	UB	UC	三相相电压最值 The extremum of three-phase voltage	UAB	UBC	UCA	三相线电压最值 The extremum of three-phase voltage
09	10	11	12	13	14	15	16
IA	IB	IC	三相电流最值 The extremum of three-phase current	PA	PB	PC	P 总 Total
17	18	19	20	21	22	23	24
QA	QB	QC	Q 总 Total	SA	SB	SC	S 总 Total
25	26	27	28	29	30	31	32
PFA	PFB	PFC	PF	F	电压不平衡 Voltage imbalance	电流不平衡 Current imbalance	中性线电流 Neutral current

开关设置 D01 D02 D03 D04	类型	延时	死区	类型	延时	过压
	DO	0000 _{ms}	0001	FL	0000	+900.0V
	高报警	低报警	零报警	欠压	过频率	欠频率
	+9000	+0000	使能	+000.0V	+99.99	+00.00
				过功率	欠功率	过电流
			+9.999k	-9.999k	+9.999A	
			L-PF	H-b. U	H-b. I	
			-1.000	+09.99	+09.99	

ACR230ELH

D01	D02	D03	D04	D01	D02	D03	D04	D01	D02	D03	D04
类型	延时	死区	高报警	类型	延时	死区	高报警	类型	延时	过线电压	欠线电压
DO	0000ms	0010	+9000	DO	0000ms	0010	+9000	FL	0000ms	+900.0V	+000.0V
低报警	零报警			低报警	零报警			过频率	欠频率	过功率	欠功率
+0000	使能			+0000	使能			+99.99Hz	+00.00Hz	+9.999kW	-9.999kW
								过电流	L-PF	H-b. U	H-b. I
								+9.999A	-1.000	+09.99	+09.99

ACR330ELH

Type	Time Delay	Dead Zone
DO	0000ms	0001
High Alarm	Low Alarm	Zero Alarm
+9000	+0000	Enable

Type	Time Delay	Over voltage
FL	0000	+900.0V
Under voltage	Over frequency	Under frequency
+000.0 V	+99.99	+00.00
Over Power	Under Power	Over Current
+9.999k	-9.999k	+9.999A

ACR230ELH

DO 1	DO 2	DO 3	DO 4
Type	Time Delay	Dead Zone	High Alarm
DO	0000ms	0010	+9000
Low Alarm	Zero Alarm		
+0000	Enable		

DO 1	DO 2	DO 3	DO 4
Type	Time Delay	Dead Zone	High Alarm
DO	0000ms	0010	+9000
Low Alarm	Zero Alarm		
+0000	Enable		

DO 1	DO 2	DO 3	DO 4
Type	Time Delay	Over voltage	Under voltage
FL	0000	+900.0V	+000.0 V
Over frequency	Under frequency	Over Power	Under Power
+99.99Hz	+00.00Hz	+9.999kw	-9.999kw
Over Current			
+9.999A			

ACR330ELH

注:

1. 三相 XX 最值表示: 高报警时为三相中最大
值, 低报警时为三相中最小值。

2. 第 2 路 DO 可设置 “33. FL” 组合报警功能,
“L-PF” (欠功率因数)、“H-b. U” (过电压不平衡,
设置为-1 断相, 判定条件至少一相 $>0.5U_e$, 至少一
相 $<0.1U_e$)、“H-b. I” (过电流不平衡, 设置为-1
断相, 判定条件至少一相 $>0.2I_e$, 至少一相 $<0.01I_e$)

3. 不平衡计算

(偏移平均值最大的值与平均值的差值)/平均
值*100%, 如果分母的平均值小于额定值, 分母为额
定值。

电压额定值 U_e : 3 相 4 线 U_e 为相电压, 菜单中设置
的 400V 的仪表为 $220V*PT$, 100V 的仪表为 $57V*PT$ 。

电流额定值 I_e : 5A 的仪表为 $5A*CT$, 1A 的仪表为
 $1A*CT$ 。

1. Three-phase XX maximum value: High Alarm
is the maximum value of three-phase, and Low
Alarm is the minimum value of three-phase.

2. The 2nd way DO can be set the "33. FL"
combination alarm function, the "L-PF"(under power
factor), the "H-b. U" (over-voltage imbalance is set as
the loss of phase -1, with determination condition of at
least one phase $>0.5U_e$ and at least one phase $<0.1U_e$),
the "H-b. I"(over-current imbalance is set as the loss
of phase -1, with thedetermination condition of at least
one phase $>0.2I_e$ and at least one phase $<0.01I_e$)

3. Unbalance factor calculation

(The difference between the maximum offset
value and the mean value)/ mean value*100%, if the
mean value of the denominator is less than the
nominal value, the denominator is the rated value.

Voltage rated value U_e : 3-phase 4-way U_e is the
phase voltage. The meter with 400V set in the menu is
 $220V*PT$, and the meter with 100V is $57V*PT$.

不平衡度下设置的参数为百分比格式，如设置为 20 表示 20%。

The parameters set under Unbalance factor are in the percentage format, for example, the setting of 20 stands for 20%.

e)变送设置

Current rated value Ie: meter of 5A is 5A*CT, and meter of 5A is 1A*CT.

e)Transmitting setting

四路模拟量输出选择,模拟变送输出可选择将电网中常见的 26 个电量 (U_A、U_B、U_C、U_{AB}、U_{BC}、U_{CA}、I_A、I_B、I_C、P_A、P_B、P_C、P_总、Q_A、Q_B、Q_C、Q_总、S_A、S_B、S_C、S_总、PF_A、PF_B、PF_C、PF、F) 隔离变送输出为 4~20mA 的直流信号。20mA 输出与二次侧额定值 Max1/Max2 相对应,取最高四位整数(小数点忽略)不足补 0。

Four channel analog output selection, analog transmitting output selection include 26 electric parameter in power network(U_A、U_B、U_C、U_{AB}、U_{BC}、U_{CA}、I_A、I_B、I_C、P_A、P_B、P_C、P Total、Q_A、Q_B、Q_C、Q Total、S_A、S_B、S_C、S Total、PFA、PFB、PFC、PF、F)4~20mA DC signal adopt isolated transmitting output.1.Max1 or Max corresponding to secondary side rating ,take integer up to 4-bit(without decimal point)zero fill to 4-bit.

例：第一次变送 M1 对应 I_a, 第二次变送 M2 对应 I_c, Max1 及 Max2 对应 20mA 的 I_a, I_c 的值(二次)。

Example:The first channel transmitting M1 corresponding to I_a, the second channel transmitting M2 corresponding to 20mA I_a.I_c value (secondary side)

	输出	类型	满度	零点
M1	4-20mA	U _{CA} V	+500.0	+000.0
M2	4-20mA	I _A A	+5.000	+000.0
M3	4-20mA	I _A A	+5.000	+000.0
M4	4-20mA	I _A A	+5.000	+000.0

输出 Output 类型 Type 满度 Full range 零点 Zero point

f)时间设置

进入用户设置界面后,按上下键选择时间设置,然后按回车键进入时间设置界面。进入时间设置界面后,按上下键选择欲设置项目,按左右键修改设置项目值。

f)Time setting:

After entering user set up interface, press the Up/Down button to select Time setting, then press Enter key to enter Time set up interface .After entering Time setting interface, press the Up/Down button to select item to be set, press the Left/Right button to revise setting item value.

注：不合法时间不可保存(例如：不合法时间 2008 年 1 月 5 日 25 点 05 分则无法输入)

Note:The illegal time can not be saved (For example: illegal time 05/01/2008 25:05 can not be input)

时间 设置	2015 - 10 - 13
	18 : 05 : 22
	背光常亮 关
	抄表日 01
	背光亮度 43

Time settings	2015-10-13	
	18:05:22	
	Backlight Normally ON	OFF
	Meter reading date	01
	Backlight Brightness	43

g)其他设置

进入用户设置界面后,按上下键选择其它设置,然后按回车键进入其他设置界面。按上下键选择欲设置项目,按左右键清除设置项目值。电度清零界面包括抄表日设置,清除电度和事件清除。

g)other setting:

After entering user setting interface, press the Up/Down button to select other setting , then press Enter key to enter other setting interface .After entering Time setting interface, press the Up/Down button to select item to be set, press the Left/Right button to revise setting item value. KWH-value zero clearing interface include to set Meter reading day ,to clear KWH-value and event.

注：如需清除电度则选择“是”,再按回车键后,电能将被清零并且不可恢复,同时最大需量的数据也被清零。脉冲常数实际值是显示值的100倍,如脉冲液晶显示为100,实际值为10000。

Note:when clearing KWH-value ,select “Yes” and press Enter key, then Electric energy will be zero clearing and can not be restored. While the maximum demand data will be zero clearing.

其他 设置	清除电能 否
	清除事件 否
	清除极值 否
	电能显示 二次侧
	脉冲常数 0100

h)版本信息：开机显示版本信息、用户也可在该界面下查看仪表相关版本信息。

h)Version information: after power on the version information is displaying, under this interface, user can look over the related version information.

i)设置保存：在用户设置好相关的参数后,按

回车键出现数据保存的界面,如需要保存按左键选

择“是”然后回车；如不需要保存选择“否”然后回车，可退出设置界面。

parameters, user press Enter key, save data Interface appear, if need, press left key to select” Yes” and press Enter key; if no need, select” No” and press Enter key to exit interface setting.

i)Save setting: After setting related

数据保存	
是	<input checked="" type="checkbox"/> 否

Savedata	
YES	<input checked="" type="checkbox"/> NO

8 通讯说明 Communication description

8.1 简介 General

ACR 系列谐波表通讯采用 MODBUS-RTU 通讯协议，MODBUS 协议详细定义了校验码、数据序列等，这些都是特定数据交换的必要内容。

Communication of ACR Harmonic meters adopt MODBUS-RTU Communication protocol, MODBUS protocol define check code, data sequence etc. In detail, these are necessary content for specific data exchange.

8.2 通讯地址表 Communication Address Table

地址 Address	名称 Name	类型 Type	备注 Note	word
0	仪表地址 Meter address	R/W	仪表在网络节点中的地址(001---127) Network node meter Address (001--127)	1
1	通讯速率 Communication speed	R/W	0--4800bps; 4--2400bps 1--9600bps; 5--1200bps 2--19200bps; 3--38400bps(默认通讯速率). (Default Communication speed).	1
2	通讯校验方式 Communication check mode	R/W	0--无校验位(默认的方式) 0-No parity bit(Default mode); 1--奇校验位; 1-Odd parity bit; 2--偶校验位. —Even parity bit. 3--2 bits	1
3	接线方式 Wiring mode	R/W ACR230ELH ACR330ELH	0--单相 ; 0--Single phase; 1--3 相 3 线; 1—3-phase 3—wire; 2--3 相 4 线. 2—3-phase 4-wire.	1
		R/W ACR220ELH	0--3 相 3 线; 0—3-phase 3-wire;	

		ACR320ELH	1--3 相 4 线. 1—3-phase 4-wire.	
4	电压等级 Voltage level	R/W	0--100V; 1--400V; 2--660V.	1
5	电流等级 Current level	R/W	0--1A、 1--5A.	1
6	电压变比 Voltage transformation ratio	R/W	电压变比(0001---9999). Voltage transformation ratio(0001---9999).	1
7	电流变比 Current transformation ratio	R/W	电流变比(0001---9999). Current transformation ratio(0001---9999).	1
8	背光延时时间 Backlight delay time	R/W ACR320ELH ACR220ELH	设置为 0 时, 背光常亮; Setting as 0,backlight lights; 设置为 1-255 时, 背光在 1-255 秒后熄灭. Setting as 1-255,after 1-255 seconds backlight go out.	1
9	继电器 1 延时时间 Relay 1 delay time		设置为 0 时, 继电器为电平控制方式; Setting as 0,relay 1 adopt level control mode;	1
10	继电器 2 延时时间 Relay 2 delay time		设置为 1—255 时, 继电器为脉冲控制方式, 单位 0.01 秒.	1
11	继电器 3 延时时间 Relay 3 delay time		Setting as 1-255,relay adopt pulse control mode,Unit :0.01second.	1
12	继电器 4 延时时间 Relay4 delay time			1
21-23	复费率时段 1 Multi-rate time period 1	R/W	复费率信息分为 8 个时段、四种费率; 每个时段占三个字: 第一个字为时、第二个字为分、第三个字为费率种类; ACR220ELH、ACR320ELH 为四种费率, 分别为 : 0—尖 1--峰、2--平、3--谷。ACR230ELH、ACR330ELH 为三种费率, 分别为 : 1--峰、2--平、3--谷。 Information about multi-rate:8 time period、4 rates; Each period of time occupies 3 bytes:the first byte is for hour、the second is for minute、the third is for rate;ACR220ELH、ACR320ELH is four rates: 0-tip, 1-peak,2-Flat, 3-valley. ACR230ELH、ACR330ELH is three rates : 1-peak,2-Flat, 3-valley.	3
24-26	复费率时段 2 Multi-rate time period 2	R/W		3
27-29	复费率时段 3 Multi-rate time period 3	R/W		3
30-32	复费率时段 4 Multi-rate time period 4	R/W		3
33-35	复费率时段 5 Multi-rate time period 5	R/W		3
36-38	复费率时段 6 Multi-rate time period 6	R/W		3
39-41	复费率时段 7 Multi-rate time period 7	R/W		3
42-44	复费率时段 8 Multi-rate time period 8	R/W		3
53	第一路开关量输入	RO	有开关量输入时为 1, 无开关量输入时	1

	First channel Switching input		为 0. Switching as 1,non-switching as 0.	
54	第二路开关量输入 Second channel Switching input	RO		1
55	第三路开关量输入 Third channel Switching input	RO		1
56	第四路开关量输入 Fourth channel Switching input	RO		1
57	第五路开关量输入 Fifth channel Switching input	RO		1
58	第六路开关量输入 Sixth channel Switching input	RO		1
59	第七路开关量输入 Seventh channel Switching input	RO		1
60	第八路开关量输入 Eighth channel Switching input	RO		1
61	第一路开关量输出 First channel Switching output	R/W	写 1 时输出继电器触点闭合, Writing 1,Output relay contact is closed, 写 0 时输出继电器触点分开. Writing 0,Output relay contact is opening.	1
62	第二路开关量输出 Second channel Switching output			1
63	第三路开关量输出 Third channel Switching output			1
64	第四路开关量输出 Fourth channel Switching output			1
128	年 Year	R/W	时间; // BCD 码格式. Time://BCD code format. 设置时间时需要使用 10H 命令来设置所有的时间	1
129	月 Month	R/W		1
130	日 Day	R/W		1
131	时 Hour	R/W		1
132	分 Minute	R/W		1
133	秒 Second	R/W		1
140	Ua、Ub 之间的电压角度 Voltage angle of Ua and Ub	RO	电压角度小数点位数: 1 Decimal places of voltage angle:1	1
141	Ub、Uc 之间的电压角度 Voltage angle of Ub and Uc	ACR320ELH ACR220ELH		1

142	Uc、Ua 之间的电压角度 Voltage angle of Uc and Ua			1
143-148	事件记录 1 Event record 1	RO	保留 retain	6
149-154	事件记录 2 Event record 2	RO	保留 retain	6
155-160	事件记录 3 Event record 3	RO	保留 retain	6
161-166	事件记录 4 Event record 4	RO	保留 retain	6
167-172	事件记录 5 Event record 5	RO	保留 retain	6
173-178	事件记录 6 Event record 6	RO	保留 retain	6
179-184	事件记录 7 Event record 7	RO	保留 retain	6
185-190	事件记录 8 Event record 8	RO	保留 retain	6
191-196	事件记录 9 Event record 9	RO	保留 retain	6
197-202	事件记录 10 Event record 10	RO	保留 retain	6
203-208	事件记录 11 Event record 11	RO	保留 retain	6
209-214	事件记录 12 Event record 12	RO	保留 retain	6
215-220	事件记录 13 Event record 13	RO	保留 retain	6
221-226	事件记录 14 Event record 14	RO	保留 retain	6
227-232	事件记录 15 Event record 15	RO	保留 retain	6
233-238	事件记录 16 Event record 16	RO	保留 retain	6
242	中性线电流 Neutral current	RO	二次侧 电流小数点位数: 3 Secondary side Current decimal Point digital:3	1
243	相电压 Uan Phase Voltage Uan	RO	二次侧 电压小数点位数: 1 Secondary side Voltage decimal Point digital:1	1
244	相电压 Ubn Phase Voltage Ubn	RO	二次侧 Secondary side	1
245	相电压 Ucn Phase Voltage Ucn	RO	二次侧 Secondary side	1
246	线电压 Uab	RO	二次侧	1

	Line Voltage Uab		Secondary side	
247	线电压 Ubc Line Voltage Ubc	RO	二次侧 Secondary side	1
248	线电压 Uca Line Voltage Uca	RO	二次侧 Secondary side	1
249	相电流 Ia Phase Current Ia	RO	二次侧 电流小数点位数: 3 Secondary side Current decimal Point digital:3	1
250	相电流 Ib Phase Current Ib	RO	二次侧 Secondary side	1
251	相电流 Ic Phase Current Ic	RO	二次侧 Secondary side	1
252	频率 F Frequency F	RO	频率小数点位数: 2 Frequency decimal Point digital:2	1
253-254	A 相有功功率 Pa Phase A Active power Pa	RO	二次侧 有功功率 小数点位数: 2 Secondary side Active power decimal Point digital:2	2
255-256	B 相有功功率 Pb Phase B Active power Pb	RO	二次侧 Secondary side	2
257-258	C 相有功功率 Pc Phase C Active power Pc	RO	二次侧 Secondary side	2
259-260	总有功功率 P 总 Total.Active power PTotal	RO	二次侧 Secondary side	2
261-262	A 相无功功率 Qa Phase A Reactive power Qa	RO	二次侧 无功功率 小数点位数: 2 Secondary side Reactive power decimal Point digital:2	2
263-264	B 相无功功率 Qb Phase B Reactive power Qb	RO	二次侧 Secondary side	2
265-266	C 相无功功率 Qc Phase C Reactive power Qc	RO	二次侧 Secondary side	2
267-268	总无功功率 Q 总 TotalReactive power QTotal	RO	二次侧 Secondary side	2
269-270	A 相视在功率 Sa Phase A Apparent powerSa	RO	二次侧 视在功率 小数点位数: 2 Secondary side Apparent power decimal Point digital:2	2
271-272	B 相视在功率 Sb Phase B Apparent powerSb	RO	二次侧 Secondary side	2
273-274	C 相视在功率 Sc Phase C Apparent powerSc	RO	二次侧 Secondary side	2
275-276	总视在功率 S 总 TotalApparent power STotal	RO	二次侧 Secondary side	2
277	A 相功率因数 Phase A power factor	RO	功率因数 小数点位数: 3 power factordecimal Point digital:3	1
278	B 相功率因数	RO		1

	Phase B power factor			
279	C 相功率因数 Phase C power factor	RO		1
280	总功率因数 Total power factor	RO		1
281	A 相波峰系数 Phase A crest factor	RO ACR230ELH ACR330ELH	电压波峰系数小数点位数: 3 Crest factor decimal Point digital:3	1
282	B 相波峰系数 Phase B crest factor			1
283	C 相波峰系数 Phase C crest factor			1
284	A 相电话波形因子 Phase A THFF		电话波形因子小数点位数: 2 THFF decimal Point digital:2	1
285	B 相电话波形因子 Phase B THFF			1
286	C 相电话波形因子 Phase C THFF			1
287	A 相电流 K 系数 Phase A Current K factor		K 系数 小数点位数: 2 K factor decimal Point digital:2	1
288	B 相电流 K 系数 Phase B Current K factor			1
289	C 相电流 K 系数 Phase C Current K factor			1
299	电压不平衡度 Unbalance factor of current	RO	电压不平衡度 小数点位数: 1 Unbalance factor of current decimal Point digital:1	1
300	电流不平衡度 Unbalance factor of current	RO	电流不平衡度 小数点位数: 1 Unbalance factor of current decimal Point digital:1	1
301-302	最大需量 Maximum demand	RO	最大需量 小数点位数: 2 Maximum demand decimal Point digital:2	2
303-306	最大需量发生时间 Maximum demand occurrence time	RO	时间; // BCD 码格式. Time;// BCD code format (month,day,hour minute)	4
333-334	本月有功峰电能 This month active Peak Electric energy	RO	二次侧电能, 2 位小数点 Secondary side Electric energy 2-bit decimal Point	2
335-336	本月有功平电能 This month active Flat Electric energy	RO	二次侧电能, 2 位小数点 Secondary side Electric energy 2-bit decimal Point	2
337-338	本月有功谷电能 This month active Valley Electric energy	RO	二次侧电能, 2 位小数点 Secondary side Electric energy 2-bit decimal Point	2
339-340	本月有功总电能	RO	二次侧电能, 2 位小数点	2

	This month active Total Electric energy		Secondary side Electric energy 2-bit decimal Point	
341-342	上月有功峰电能 Last month active Peak Electric energy	RO	二次侧电能，2位小数点 Secondary side Electric energy 2-bit decimal Point	2
343-344	上月有功平电能 Last month active Flat Electric energy	RO	二次侧电能，2位小数点 Secondary side Electric energy 2-bit decimal Point	2
345-346	上月有功谷电能 Last month active Valley Electric energy	RO	二次侧电能，2位小数点 Secondary side Electric energy 2-bit decimal Point	2
347-348	上月有功总电能 Last month active Total Electric energy	RO	二次侧电能，2位小数点 Secondary side Electric energy 2-bit decimal Point	2
349-350	上上月有功峰电能 Month before last active Peak Electric energy	RO	二次侧电能，2位小数点 Secondary side Electric energy 2-bit decimal Point	2
351-352	上上月有功平电能 Month before last active Flat Electric energy	RO	二次侧电能，2位小数点 Secondary side Electric energy 2-bit decimal Point	2
353-354	上上月有功谷电能 Month before last active Valley Electric energy	RO	二次侧电能，2位小数点 Secondary side Electric energy 2-bit decimal Point	2
355-356	上上月有功总电能 Month before last active Total Electric energy	RO	二次侧电能，2位小数点 Secondary side Electric energy 2-bit decimal Point	2
357-358	总有功峰电能 Total active Peak Electric energy	RO	二次侧电能，2位小数点 Secondary side Electric energy 2-bit decimal Point	2
359-360	总有功平电能 Total active Flat Electric energy	RO	二次侧电能，2位小数点 Secondary side Electric energy 2-bit decimal Point	2
361-362	总有功谷电能 Total active Valley Electric energy	RO	二次侧电能，2位小数点 Secondary side Electric energy 2-bit decimal Point	2
363-364	总复费率有功电能 Total multi-rate active Electric energy	RO	二次侧电能，2位小数点 Secondary side Electric energy, 2-bit decimal point	2
365-366	正向有功电能 EPI Forward active Electric energy EPI	RO	二次侧电能，2位小数点 Secondary side Electric energy, 2-bit decimal point	2
367-368	反向有功电能 EPE Backward active Electric energy EPE	RO	二次侧电能，2位小数点 Secondary side Electric energy, 2-bit decimal point	2
369-370	正向无功电能 EQL	RO	二次侧电能，2位小数点	2

	Forward reactive Electric energy EQI		Secondary side Electric energy, 2-bit decimal point	
371-372	反向无功电能 EQC Backward reactive Electric energy EQC	RO	二次侧电能, 2 位小数点 Secondary side Electric energy, 2-bit decimal point	2
373-402	A 相电压 2—31 次谐波含有率 A Phase Voltage 2-31 order harmonic ratio	RO	A 相电压 2-31 次谐波; 小数点位数: 2 A Phase Voltage 2-31 order harmonic; 2-bit decimal point	30
403-432	B 相电压 2—31 次谐波含有率 B Phase Voltage 2-31 order harmonic ratio	RO	B 相电压 2-31 次谐波, 小数点位数: 2 B Phase Voltage 2-31 order harmonic, 2-bit decimal point	30
433-462	C 相电压 2—31 次谐波含有率 C Phase Voltage 2-31 order harmonic ratio	RO	C 相电压 2-31 次谐波, 小数点位数: 2 C Phase Voltage 2-31 order harmonic, 2-bit decimal point	30
463-492	A 相电流 2—31 次谐波含有率 A Phase Current 2-31 order harmonic ratio	RO	A 相电流 2-31 次谐波, 小数点位数: 2 A Phase Current 2-31 order harmonic, 2-bit decimal point	30
493-522	B 相电流 2—31 次谐波含有率 B Phase Current 2-31 order harmonic ratio	RO	B 相电压 2-31 次谐波, 小数点位数: 2 B Phase Current 2-31 order harmonic, 2-bit decimal point	30
523-552	C 相电流 2—31 次谐波含有率 C Phase Current 2-31 order harmonic ratio	RO	C 相电流 2-31 次谐波, 小数点位数: 2 C Phase Current 2-31 order harmonic, 2-bit decimal point	30
553	A 相电压总谐波畸变率 A Phase Voltage Total harmonic distortion	RO	A 相电压总谐波含量; 小数点位数: 2 A Phase Voltage Total harmonic content; decimal point digital: 2	1
554	B 相电压总谐波畸变率 B Phase Voltage Total harmonic distortion	RO	B 相电压总谐波含量; 小数点位数: 2 B Phase Voltage Total harmonic content; decimal point digital: 2	1
555	C 相电压总谐波畸变率 C Phase Voltage Total harmonic distortion	RO	C 相电压总谐波含量; 小数点位数: 2 C Phase Voltage Total harmonic content; decimal point digital: 2	1
556	A 相电流总谐波畸变率 A Phase Current Total harmonic distortion	RO	A 相电流总谐波含量; 小数点位数: 2 A Phase Current Total harmonic content; decimal point digital: 2	1
557	B 相电流总谐波畸变率 B Phase Current Total harmonic distortion	RO	B 相电流总谐波含量; 小数点位数: 2 B Phase Current Total harmonic content; decimal point digital: 2	1
558	C 相电流总谐波畸变率	RO	C 相电流总谐波含量; 小数点位数: 2	1

	C Phase Current Total harmonic distortion		C Phase Current Total harmonic content;decimal point digital:2	
559-590	A 相电压采样点(32 点/波) A Phase Voltage sampling point(32 point/wave)	RO	A 相电压采样点 A Phase Voltage sampling point	32
591-622	B 相电压采样点(32 点/波) B Phase Voltage sampling point(32 point/wave)	RO	B 相电压采样点 B Phase Voltage sampling point	32
623-654	C 相电压采样点(32 点/波) C Phase Voltage sampling point(32 point/wave)	RO	C 相电压采样点 C Phase Voltage sampling point	32
655-686	A 相电流采样点(32 点/波) A Phase Current sampling point(32 point/wave)	RO	A 相电流采样点 A Phase Current sampling point	32
687-718	B 相电流采样点(32 点/波) B Phase Current sampling point(32 point/wave)	RO	B 相电流采样点 B Phase Current sampling point	32
719-750	C 相电流采样点(32 点/波) C Phase Current sampling point(32 point/wave)	RO	C 相电流采样点 C Phase Current sampling point	32
1000	DIDO 状态 DIDO state	R/W	高字节为 DI(bit0 为 DI1,bit1 为 DI2,以此类推, bit7 为 DI8),低字节为 DO (bit0 为 DO1,bit1 为 DO2,以此类推, bit7 为 DO8) High bytes DI (bit 0 as DI1, bit 1 as DI2, like this, bit 7 as DI8), low bytes DO (bit 0 as DO1, bit 1 as DO2, like this, bit 7 as DO8)	1
1001	第 1 路报警选择 First way alarm selection	R/W	0-32, 详见 7.1.5 表中的对应关系 如总有功功率报警, 此值为 16. 0-32, details given in correlation in table 7.1.5, e.g. total active power alarm, value 16	1
1002	第 1 路报警延时 First way alarm delay	R/W	0-9999 单位:s; 如总有功功率报警, 此值为 16. 0-9999 unit: s; e.g. total active power alarm, the value being 16	1
1003	第 1 路报警死区 First way alarm dead zone	R/W	-9999 – 9999 详见 7.1.5 , 例: 显示值为 66.00Kw,通讯值为 6600 -9999 – 9999 details given in 7.1.5, e.g. reading 66.00Kw, communication value 6600	1
1004	第 1 路报警高报警 First way high alarm	R/W		1
1005	第 1 路报警低报警	R/W		1

	First way low alarm			
1006	第 1 路报警 0 报警 First way 0 alarm	R/W	0 – 1 (0: 使能, 1: 禁止) 0 – 1 (0: enabled, 1: disabled)	1
1007-1012	第 2 路 (同上) Second way (same as above)	R/W	比第一路多一种组合报警选择, 种类选择为 0-33 (取值为 33 时, 对应设置地址为 1030-1037 有效), 其余同第一路 One more combination alarm selection than the first way, type selection 0-33 (in case of value 33, corresponding set address 1030-1037 effective), the remaining same as first way	6
1013-1018	第 3 路 (同上) Third way (same as above)	R/W	同第一路 Same as first way	6
1019-1024	第 4 路 (同上) Fourth way (same as above)	R/W	同上 Same as above	6
1030	组合报警参数 过频率 Combination alarm parameter Over frequency	R/W	-9999 – 9999 仅限第二路报警为组合报警时有效, 详见 7.1.5; 例: 显示值为 66.00Kw, 通讯值为 6600 -9999 – 9999 only effective when the second way alarm is the combination alarm, details given in 7.1.5; e.g. reading 66.00Kw, communication value 6600	1
1031	欠频率 Under frequency	R/W		1
1032	过功率 Over power	R/W		1
1033	欠功率 Under power	R/W		1
1034	过电流 Over current	R/W		1
1035	欠功率因数 Under power factor	R/W		1
1036	过电压不平衡 Over voltage unbalance	R/W	-1 – 9999 详见 7.1.5, 例: 显示值为 55.00Kw, 通讯值为 5500 -1 – 9999 details given in 7.1.5, e.g.: reading 55.00Kw, communication value 5500	1
1037	过电流不平衡 Over current unbalance	R/W		1
1038	组合报警状态 Combination alarm state	RO	第 0 位表示过电压报警状态, 第一位表示欠电压报警状态, 依次类推到第 9 位 0 bit indicates over voltage alarm	1

			state, first bit indicates under voltage alarm state, in the same manner till bit 9	
1040	第 1 路变送选择 (低字节有效) First way transmission selection (low bytes effective)	R/W	0-25 详见 7.1.6 表格中的对应关系; 如总有功功率报警, 此值为 12. 0-25 details given in correlation in table 7.1.6; e.g. total active power alarm, the value being 12	1
1041	第 1 路高变送 First way high transmission	R/W	-9999 – 9999 详见 7.1.6; 例: 显示值为 50.00Kw, 通讯值为 5000 -9999 – 9999 details given in 7.1.6; e.g. reading 50.00Kw, communication value 5,000	1
1042	第 1 路低变送 First way low transmission	R/W		1
1043-1045	第 2 路变送 Second way transmission	R/W		3
1046-1048	第 3 路变送 Third way transmission	R/W		3
1049-1051	第 4 路变送 Fourth way transmission	R/W		3
1100-1102	DLT/645 地址 DLT/645 address	R/W		3
1103	第二路通讯的通讯速率 Second way communication speed	R/W	0--4800bps; 4--2400bps 1--9600bps; 5--1200bps 2--19200bps; 3--38400bps(默认通讯速率 default communication speed).	1
1104	第二路通讯校验方式 Second way communication calibration mode	R/W	0--无校验位(默认的方式);no calibration bit (default mode) 1--奇校验位;odd calibration bit 2--偶校验位.even calibration bit 3--2 bits	1
1200-1211	1 时区参数 Time interval 1 parameter	R/W	1 时区分为 8 个时段; 每个时段占 1.5 个字, 第一个字节为时, 第二个字节为分, 第三个字节为费率种类, 四种费率分别为 0-尖, 1-峰, 2-平, 3-谷 Time interval 1 has 8 time periods; each time period takes 1.5 character, the first byte being time, second byte being minute, third byte being rate type, four rates separately being 0-tip, 1-peak, 2-flat, 3-trough	27

1212-1225	2 时区参数 Time interval 2 parameter		1 时区分为 9 个时段；每个时段占 1.5 个字，第一个字节为时，第二个字节为分，第三个字节为费率种类，四种费率分别为 0-尖，1-峰，2-平，3-谷 Time interval 1 has 9 time periods; each time period takes 1.5 character, the first byte being time, second byte being minute, third byte being rate type, four rates separately being 0-tip, 1-peak, 2-flat, 3-trough	
1225-1226	时区种类选择 Time interval type selection		1225 的低 8 位为 1-8 月份的时区选择，第 8 位为 1 月份时区选择，（0：选时区 1，1：选时区 2），以此类推，第 1 位为 8 月份时区选择；1226 的高 4 位为 9-12 月份的时区选择，第 16 位为 9 月份时区选择，依次类推，第 13 位为 12 月份时区选择（0：选时区 1，1：选时区 2） 1225 low 8 bit being January-August time interval selection, eighth bit being January time interval selection, (0: select time interval 1, 1: select time interval 2), in the similar manner, bit 1 being August time interval selection; 1226 high 4 bit September-December time interval selection, bit 16 being September time interval selection, in the similar manner, bit 13 being December time interval selection (0: select time interval 1, 1: select time interval 2)	
1250-1251	历史 1 月份有功尖电能 Historical active tip electric energy in January	RO	二次测电能，2 位小数点 Secondary electric energy, 2-bit decimal points	2
1252-1253	历史 1 月份有功峰电能 Historical active peak electric energy in January	RO	同上 Same as above	2
1254-1255	历史 1 月份有功平电能 Historical active flat electric energy in January	RO	同上 Same as above	2
1256-1257	历史 1 月份有功谷电能 Historical active trough electric energy in January	RO	同上 Same as above	2
1258-1259	历史 1 月份有功总电能 Historical total active electric energy in January	RO	同上 Same as above	2

1260-1269	历史 2 月份有功电能 Historical active electric energy in February	RO	同上 Same as above	10
1270-1279	历史 3 月份有功电能 Historical active electric energy in March	RO	同上 Same as above	10
1280-1289	历史 4 月份有功电能 Historical active electric energy in April	RO	同上 Same as above	10
1290-1299	历史 5 月份有功电能 Historical active electric energy in May	RO	同上 Same as above	10
1300-1309	历史 6 月份有功电能 Historical active electric energy in June	RO	同上 Same as above	10
1310-1319	历史 7 月份有功电能 Historical active electric energy in July	RO	同上 Same as above	10
1320-1329	历史 8 月份有功电能 Historical active electric energy in August	RO	同上 Same as above	10
1330-1339	历史 9 月份有功电能 Historical active electric energy in September	RO	同上 Same as above	10
1340-1349	历史 10 月份有功电能 Historical active electric energy in October	RO	同上 Same as above	10
1350-1359	历史 11 月份有功电能 Historical active electric energy in November	RO	同上 Same as above	10
1360-1369	历史 12 月份有功电能 Historical active electric energy in December	RO	同上 Same as above	10
1370-1379	总有功电能 Total active electric energy	RO	同上 Same as above	10
2000-2061	A 相电压 2-63 次谐波含有率 Phase A voltage 2-63 harmonic content	RO	A 相电压 2-63 次谐波; 2 位小数点: 2 Phase A voltage 2-63 harmonic; decimal points: 2	62
2062-2123	B 相电压 2-63 次谐波含有率 Phase B voltage 2-63 harmonic content	RO	B 相电压 2-63 次谐波; 2 位小数点: 2 Phase B voltage 2-63 harmonic; decimal points: 2	62
2124-2185	C 相电压 2-63 次谐波含有率 Phase C voltage 2-63 harmonic content	RO	C 相电压 2-63 次谐波; 2 位小数点: 2 Phase C voltage 2-63 harmonic; decimal points: 2	62
2186-2247	A 相电流 2-63 次谐波含有率	RO	A 相电流 2-63 次谐波; 2 位小数点: 2	62

	Phase A current 2-63 harmonic content		Phase A current 2-63 harmonic; decimal points: 2	
2248-2309	B 相电流 2-63 次谐波含有率 Phase B current 2-63 harmonic content	RO	B 相电流 2-63 次谐波; 2 位小数点: 2 Phase B current 2-63 harmonic; decimal points: 2	62
2310-2371	C 相电流 2-63 次谐波含有率 Phase C current 2-63 harmonic content	RO	C 相电流 2-63 次谐波; 2 位小数点: 2 Phase C current 2-63 harmonic; decimal points: 2	62
2372	A 相电压总谐波畸变率 Phase A voltage total harmonic distortion	RO	A 相电压总谐波含量; 小数点位数: 2 Phase A voltage total harmonic content; decimal points: 2	1
2373	B 相电压总谐波畸变率 Phase B voltage total harmonic distortion	RO	B 相电压总谐波含量; 小数点位数: 2 Phase B voltage total harmonic content; decimal points: 2	1
2374	C 相电压总谐波畸变率 Phase C voltage total harmonic distortion	RO	C 相电压总谐波含量; 小数点位数: 2 Phase C voltage total harmonic content; decimal points: 2	1
2375	A 相电流总谐波畸变率 Phase A current total harmonic distortion	RO	A 相电流总谐波含量; 小数点位数: 2 Phase A current total harmonic content; decimal points: 2	1
2376	B 相电流总谐波畸变率 Phase B current total harmonic distortion	RO	B 相电流总谐波含量; 小数点位数: 2 Phase B current total harmonic content; decimal points: 2	1
2377	C 相电流总谐波畸变率 Phase C current total harmonic distortion	RO	C 相电流总谐波含量; 小数点位数: 2 Phase C current total harmonic content; decimal points: 2	1
2378	A 相电压基波有效值 Phase A voltage fundamental wave effective value	RO	A 相电压基波有效值; 小数点位数: 1 Phase A voltage fundamental wave effective value; decimal points: 1	1
2379	B 相电压基波有效值 Phase B voltage fundamental wave effective value	RO	B 相电压基波有效值; 小数点位数: 1 Phase B voltage fundamental wave effective value; decimal points: 1	1
2380	C 相电压基波有效值 Phase C voltage fundamental wave effective value	RO	C 相电压基波有效值; 小数点位数: 1 Phase C voltage fundamental wave effective value; decimal points: 1	1
2381	A 相电流基波有效值 Phase A current fundamental wave effective value	RO	A 相电流基波有效值; 小数点位数: 3 Phase A current fundamental wave effective value; decimal points: 3	1
2382	B 相电流基波有效值 Phase B current fundamental wave effective value	RO	B 相电流基波有效值; 小数点位数: 3 Phase B current fundamental wave effective value; decimal points: 3	1

	value			
2383	C 相电流基波有效值 Phase C current fundamental wave effective value	RO	C 相电流基波有效值; 小数点位数: 3 Phase C current fundamental wave effective value; decimal points: 3	1
2400-2461	A 相电压 2-63 次谐波含量 Phase A voltage 2-63 harmonic content	RO	A 相电压 2-63 次谐波; 小数点位数: 2 Phase A voltage 2-63 harmonic; decimal points: 2	62
2462-2523	B 相电压 2-63 次谐波含量 Phase B voltage 2-63 harmonic content	RO	B 相电压 2-63 次谐波; 小数点位数: 2 Phase B voltage 2-63 harmonic; decimal points: 2	62
2524-2585	C 相电压 2-63 次谐波含量 Phase C voltage 2-63 harmonic content	RO	C 相电压 2-63 次谐波; 小数点位数: 2 Phase C voltage 2-63 harmonic; decimal points: 2	62
2586-2647	A 相电流 2-63 次谐波含量 Phase A current 2-63 harmonic content	RO	A 相电流 2-63 次谐波; 小数点位数: 2 Phase A current 2-63 harmonic; decimal points: 2	62
2648-2709	B 相电流 2-63 次谐波含量 Phase B current 2-63 harmonic content	RO	B 相电流 2-63 次谐波; 小数点位数: 2 Phase B current 2-63 harmonic; decimal points: 2	62
2710-2771	C 相电流 2-63 次谐波含量 Phase C current 2-63 harmonic content	RO	C 相电流 2-63 次谐波; 小数点位数: 2 Phase C current 2-63 harmonic; decimal points: 2	62
2772	A 相电压总谐波含量 Phase A voltage total harmonic content	RO	A 相电压总谐波含量; 小数点位数: 1 Phase A voltage total harmonic content; decimal points: 1	1
2773	B 相电压总谐波含量 Phase B voltage total harmonic content	RO	B 相电压总谐波含量; 小数点位数: 1 Phase B voltage total harmonic content; decimal points: 1	1
2774	C 相电压总谐波含量 Phase C voltage total harmonic content	RO	C 相电压总谐波含量; 小数点位数: 1 Phase C voltage total harmonic content; decimal points: 1	1
2775	A 相电流总谐波含量 Phase A current total harmonic content	RO	A 相电流总谐波含量; 小数点位数: 3 Phase A current total harmonic content; decimal points: 3	1
2776	B 相电流总谐波含量 Phase B current total harmonic content	RO	B 相电流总谐波含量; 小数点位数: 3 Phase B current total harmonic content; decimal points: 3	1
2777	C 相电流总谐波含量 Phase C current total harmonic content	RO	C 相电流总谐波含量; 小数点位数: 3 Phase C current total harmonic content; decimal points: 3	1

注: 1、读写属性: “RO”只读, 读参量用 0X03H 命令; “R/W”可读可写, 写系统参量用 0X10H 号命令, 禁止向未列出的或不具可写属性的地址写数据。

Note: 1、Read/Write attribute: “RO” read only, this parameter use 03H command; “R/W” Read/Write ,system parameter use 10H command, Read in address, which is not listed or

without Read/Write attribute, is forbidden.

2、仪表数据采用定点数表示，小数点位数见地址表；电压电流谐波数据为百分量表示。

2.Meter data adopt fixed_point number, decimal point digital see Address table; voltage/current harmonic data adopt percentage.

8.3 通讯值与实际值对应关系（约定 Val_t 为通讯读出值，Val_s 为实际值）Communication reading value Vs actual value(Take Val_t as Communication reading value,Val_s as actual value)

8.3.1、电压、电流、功率因数、频率

该系列测量值用 Modbus-RTU 通讯规约的 03 号命令读出，每一个项目占用 1 个 word。通讯值与实际二次侧测量值之间的对应关系如下表：

8.3.1 Voltage,current,power factor ,frequency

This series measuring value is read out by Modbus-RTU protocol 03 command,each item occupy one word.Relation between communication value and actual value(secondary side measuring) is shown as below table:

适用参量 Applied parameter	对应关系 Relation	单位 Unit
电压 Voltage Uan、Ubn、Ucn、Uab、Ubc、Uca	$Val_s = Val_t / 10$	伏 V
电流 Current $I_A、I_B、I_C$	$Val_s = Val_t / 1000$	安培 A
功率因数 Power factor $PF_A、PF_B、PF_C、PF_{总}$	$Val_s = Val_t / 1000$	无单位 None
频率 Frequency FR	$Val_s = Val_t / 100$	赫兹 Hz

例：读 A 相电压 Uan, 在地址 0x00F3H 通讯读出值为 2200, 则 $Val_s = Val_t / 10 = 2200 / 10 = 220V$ 。

Example:Read A phase voltage Uan,communication reading value Val_t is 2200at address 0x00F3H,then $Val_s = Val_t / 10 = 2200 / 10 = 220V$.

8.3.2 有功功率、无功功率、视在功率及电能（二次侧；W/Var/VA/kWh）

该系列测量值用 Modbus-RTU 通讯规约的 0x03 号命令读出，每一个项目占用两个 word。通讯值与实际值之间的对应关系如下： $Val_s = Val_t / 100$ ；其中 $Val_t =$ 第一个 word $\times 65536 +$ 第二个 word。

Active power,Reactive power,Apparent Energy and Electric energy(Secondary side: W/Var/VA/kWh)

This series measuring value is read out by Modbus-RTU protocol 0x03 command,each item occupy two words.Relation between communication value and actual value is shown as below: $Val_s = Val_t / 100$;in it, $Val_t =$ First word $\times 65536 +$ second word.

例：读 A 相有功功率 Pa, 在地址 0x00FDH-0x00FEH, 0x00FDH 通讯读出值为 1, 0x00FEH 通讯读出值为 26000, 即 $Val_t = 1 \times 65536 + 26000 = 91536$, 则 $Val_s = Val_t / 100 = 915.36W$ 。

Example:Read A phase active power Pa,at address 0x00FDH-0x00FEH communication reading value is 1 at address 0x00FDH, communication reading value Val_t is 26000 at address 0x00FEH, $Val_t = 1 \times 65536 + 26000 = 91536$,then $Val_s = Val_t / 100 = 915.36W$.

8.3.3、电压波峰系数、电压波形因子、电流 K 系数、电压波峰值、电流电压正序负序零序分量及不平衡度

8.3.3.Voltage wave peak coefficient,telephone wave form factor,current K coefficient,voltage wave peak value,current/voltage positive

该系列测量值用 Modbus-RTU 通讯规约的 0x03 号命令读出，每一个项目占用 1 个 word。通讯值与实际值之间的对应关系如下表：

适用参量 Applied parameter	对应关系 Relation	单位 Unit
电压波峰系数 Crest factor	$Val_s = Val_t / 1000$	无单位 None
电话波形因子 THFF	$Val_s = Val_t / 100$	无单位 None
电流 K 系数 Current K factor	$Val_s = Val_t / 100$	无单位 None
峰值电压（二次侧值） Peak voltage(Secondary side value)	$Val_s = Val_t / 10$	伏 V V
电压电流不平衡度 Unbalance factor of Voltage and current	$Val_s = (Val_t / 10) \%$	百分量 Percentage

例：读 A 相电压波峰系数, 在地址 0x0119 通讯读出值 Val_t 为 1414, 则 $Val_s = Val_t / 1000 = 1414 / 1000 = 1.414$ 。

sequence negative sequence,zero sequence component and unbalancedness.

This series measuring value is read out by Modbus-RTU protocol 0×03 command,each item occupy one word.Relation between communication value and actual value is shown as below table:

Example:Read A phase Voltage wave peak coefficient,communication reading value “Val_t” is 1414 at address 0×0119,then $Val_s = Val_t / 1000 = 1414 / 1000 = 1.414$

8.3.4、电压电流谐波数据

该系列测量值用 Modbus-RTU 通讯规约的 0x03 号命令读出，每一个项目占用 1 个 word。通讯值与实际值之间的对应关系如下： $Val_s = (Val_t / 100) \%$

例：读 A 相电流 3 次谐波含有率, 在地址 0x01D0 通讯读出值 Val_t 为 157, 则 $Val_s = (Val_t / 100) \% = 1.57\%$

8.3.4、Voltage/current harmonic data

This series measuring value is read out by Modbus-RTU protocol 0×03 command,each item occupy one word.Relation between communication value and actual value is shown as below: $Val_s = (Val_t / 100) \%$

Example:Read current third harmonics containing rate of phase A current,communication reading value “Val_t” is 157 at address 0×01D0,then $Val_s = (Val_t / 100) \% = 1.57\%$

该系列测量值包括年、月、日、时、分、秒，用 Modbus-RTU 通讯规约的 03 号命令读出，

8.3.5、日期时间

8.3.5Time

每一个项目占用 1 个 word，为 BCD 码格式。

This series measuring value include year, month, day, hour, minute, second, is

例：读年数，MODSCAN 在 HEX 读数方式下在地址 0X0081 栏可直接读出

8.3.6、事件记录

事件记录 1-事件记录 16, 按时间发生顺序记录, 即事件记录 1 记录着最新发生事件的数据, 事件记录 16 记录着最早发生事件的数据, 各事件记录的数据格式如下:

	高 8 位 High 8-bit	低 8 位 Low 8-bit
地址 1 Adress 1	第 0 位 (最低位): 0 为 D0, 1 为 DI Bit 0(The lowest bit): 0 is D0, 1 is DI 第 7 位 (最高位): 0 为断开, 1 为闭合 Bit 7(The highest bit): 0 is disconnected, 1 is closed	开关量序列号: Serial number of switching capacity 0 为第一路, 1 为第二路, 以此类推 0 is first, 1 is second and so on
地址 2 Adress 2	报警类型: 见 7.1.5 Alarm type: See 7.1.5	组合报警类型 ^注 Combined alarm ^{note}
地址 3 Adress 3	Year (时间戳年)	Month (时间戳月)
地址 4 Adress 4	Day (时间戳日)	Hour (时间戳时)
地址 5 Adress 5	Minute (时间戳分)	Second (时间戳秒)
地址 6 Adress 6	报警时的数值 (断相时记录三相中的最小值) Value of the alarm (the smallest is recorded when it is open-phase)	

注: 0-过线电压、1-欠线电压、2-过频率、3-欠频率、4-过功率、5-欠功率、6-过电流、7-欠功率因数、8-过电压不平衡、9-过电流不平衡

例: D01 为 A 相电压报警, 在 15 年 1 月 22 日 14 时 56 分 32 秒发生欠压报警, 报警值为 172.2V, 则对应寄存器的值如下:

	高 8 位 High 8-bit	低 8 位 Low 8-bit
地址 1 Adress 1	128	0
地址 2 Adress 2	1	0
地址 3 Adress 3	15	1

read out by Modbus -RTU protocol 0x03 command, each item occupy one word, adopt BCD code format.

Example: Read the number of years, MODSCAN in HEX reading mode can be read directly in the address bar 0X0081

8.3.6、Event record

Event record 1- Event record 16 are recorded in chronological order, Event record 1 contains the data of latest event, Event record 16 contains the data of earliest event. The data format is as follows

Note: 0-Over line voltage、2-Over frequency、3-Under frequency、4-Under power、5-Over power、6-Over current、7-Under power factor、8-Over voltage unbalance、9-Over current unbalance.

Example: D01 is alarm of A phase voltage, under voltage alarm occurs in 15 January 22nd 14:56:32, the value is 172.2V, the corresponding register value is as follows:

Adress 3		
地址 4 Adress 4	22	14
地址 5 Adress 5	56	32
地址 6 Adress 6	1722	

9 DL/T-645 通讯指南 Communication Guideline

主要讲述如何利用软件通过通讯口来操控该系列仪表。内容的掌握需要您具有 DL/T645-1997 协议的知识储备并且通读了本册其它章节所有内容, 对本产品功能和应用概念有较全面了解。同时需将通讯 2 口设置为 DL/T-645 协议, 本章内容包括: DL/T645-1997 协议简述、通讯应用格式详解、本机的应用细节及参量地址表。

It mainly specifies how to resort to the software to control the instrument series via the communication port. The user shall have knowledge of DL/T645-1997 Communication Protocol and thoroughly read all other contents herein before a relatively comprehensive understanding on the functions and applications of the product. In the meantime, set communication port 2 as DL/T-645 Protocol. This chapter includes: DL/T645-1997 Protocol Overview, detailed explanation on the communication application format, application details and parameters address table of the instrument.

9.1 DL/T645-1997 协议简述 DL/T645-1997 protocol overview

该仪表使用的是符合 DL/T645-1997 规范的通讯协议, DL/T645-1997 协议详细定义了校验码、数据、序列等, 这些都是特定数据交换的必要内容。DL/T645-1997 协议在一根通讯线上使用主从应答式连接(半双工), 这意味着在一根单独的通讯线上信号沿着相反的两个方向传输。首先, 主计算机的信号寻址到一台唯一的终端设备(从机), 然后, 终端设备发出的应答信号以相反的方向传输给主机。

This instrument conforms to DL/T645-1997 Communication Protocol. DL/T645-1997 Communication Protocol specifies in detail the calibration code, data, sequence, etc, which are indispensable to the specific data exchange. DL/T645-1997 Communication Protocol uses master-slave response connection (half duplex) in one communication line. It means bidirectional transmission along one standalone communication line. First, the host computer signal retrieves unique terminal equipment (slave), and then, the response signal sent by the terminal equipment is transmitted to the host in the opposite direction.

DL/T645-1997 协议只允许在主机(PC, PLC 等)和终端设备之间通讯, 而不允许独立的终端设备之间的数据交换, 这样各终端设备不会在它们初始化时占据通讯线路, 而仅限于响应到达本机的查询信号。

DL/T645-1997 Protocol only allows communication between host (PC, PLC, etc) and terminal equipment instead of exchange of data in between the standalone terminal equipment. Thus, the terminal equipment will not occupy communication line during initializing. Instead, it's

only limited to response to the corresponding

9.2 传输方式 Transmission mode

传输方式是指一个数据帧内一系列独立的数据结构以及用于传输数据的有限规则，下面定义了与 DL/T645-1997 协议- RTU 方式相兼容的传输方式。

- 每个字节的位
- 1 个起始位
- 8 个数据位，最小的有效位先发送
- 1 个偶校验位
- 1 个停止位
- 错误检测和校验

9.3 协议 Protocol

当数据帧到达终端设备时，它通过一个简单的“端口”进入被寻址到的设备，该设备去掉数据帧的“信封”（数据头），读取数据，如果没有错误，就执行数据所请求的任务，然后，它将自己生成的数据加入到取得的“信封”中，把数据帧返回给发送者。返回的响应数据中包含了以下内容：终端从机地址 (Address)、被执行了的命令(Function)、执行命令生成的被请求数据(Data)和一个校验码(Check)。发生任何错误都不会有成功的响应，或者返回一个错误指示帧。

9.3.1 数据帧格式

68H	A0	A1	A2	A3	A4	A5	68H	C	L	DI0	DI1	N1	...	Nm	CS	16H
起始符 Initial symbol	地址域 Address field						帧起始 Frame starting	控制码 Control code	数据长度 Data length	数据标识 Data label	数据 Data				校验码 Calibra tion code	结束符 End symbol

a) 帧起始符 68H

标识一帧数据的开始，其值为 68H

b)地址域 A0~A5

地址域由 6 个字节（8 位二进制码）组成，每字节 2 位 BCD 码。地址长度可达 12 位十进制数，ACR220ELH(ACR320ELH)只用 A0 与 A1，其中 A0 为地址的低字节，A1 为地址的高字节，组成地址范围为 1~247，此地址数据可在仪表中进行任意

enquiry signal.

The transmission mode represents one series of independent data structure within one data frame and the limited rules for data transmission. Definitions of transmission mode compatible with DL/T645-1997 Protocol- RTU mode are as follows.

- each byte bit
- 1 initial bit
- 8 data bits; the smallest effective bit will be sent first
- 1 even calibration bit
- 1 stop bit
- Error checking and calibration

When the data frame arrives at the terminal equipment, it resorts to one simple "port" to access the retrieved equipment. Such equipment will erase data frame "envelop" (data header) and read data. If there is no error, execute the assignment required by the data. And then, it will add the generated data into the obtained "envelop" and return the data frame to the sender. The returned response data contain contents below: terminal slave address (Address), executed command (Function), requested data (Data) generated by the execution command and one calibration code (Check). In case of any error, there won't be success response or return one error instruction frame.

9.3.1Data frame format

a) Frame initial symbol 68H

Mark beginning of one frame of data and its value is 68H

b)Address field A0~A5

设置。其余（A2~A5）全部用 00 填充。这些位标明了用户指定的终端设备的地址，该设备将接收来自与之相连的主机数据。每个终端设备的地址必须是唯一的，仅仅被寻址到的终端会响应包含了该地址的查询。当终端发送回一个响应，响应中的从机

地址数据便告诉了主机哪台终端正与之进行通信。
当地址为 999999999999H 时，为广播地址。

The address length may reach 12-bit decimal number; ACR220ELH(ACR320ELH) only uses A0 and A1, thereinto, A0 represents low bytes of the address while A1 represents high bytes of the address and the formed address scope is 1~247; the address data can be randomly set in the instrument. The remaining (A2~A5) are fully filled by 00. Such bits mark the user specified terminal equipment address and such equipment will receive the connected host data. Each terminal equipment address must be unique and only the retrieved terminal will respond to the contained address enquiry. When the terminal returns one response, the responding slave address data tell host which terminal is conducting communication. When the address is 999999999999H, it's broadcast address.

The address field is composed of 6 bytes (8 bits binary code) and each byte has 2-bit BCD code.

c)控制码 C

功能域代码告诉了被寻址到的终端执行何种功能。下表列出了该系列仪表用到的功能码，以及它们的意义和功能。

c)Control code C

The function field code tells the function to be executed by the retrieved terminal. The table below presents the function code used by the instrument series and their meanings and functions.

代码 Code	意义 Meaning	行为 Action
01H	读数据 Read data	从 ACR220ELH/ACR320ELH 中读取数据 Read data from ACR220ELH/ACR320ELH
81H	读数据应答 Read data response	ACR220ELH/ACR320ELH 对读数据的应答 ACR220ELH/ACR320ELH response to reading data
04H	写数据 Write data	将数据写入 ACR220ELH/ACR320ELH 中 Write data into ACR220ELH/ACR320ELH
84H	写数据应答 Write data response	ACR220ELH/ACR320ELH 对写数据的应答 ACR220ELH/ACR320ELH response to writing data
C4H 或 C2H C4H or C2H	错误应答 Wrong response	接收到的数据错误 Received data wrong

d) 数据域（数据标识与数据）长度 L
数据域的字节长度。读数据时 $L \leq 200$ ，写数据时 ≤ 50 ， $L=0$ 时表示无数据域。

d) Data field (data label and data) length L
Data field byte length; read data $L \leq 200$, write data ≤ 50 , $L = 0$ means there is no data field

e)错误校验 CS

从帧起始符开始到校验码之前的所有各字节的模 256 的和，即各字节二进制算术和，不计超过 256 的溢出值。

e)Error calibration CS

namely binary arithmetic sum of all bytes is no more than 256 overflow value.

f) 结束符 End

f) symbol 16H

标识一帧数据的结束

Indicate the end of one frame of data

9.3.2 传输

9.3.2 Transmission

a) 前导字节

a) Lead byte

在发送帧信息之前，可先传送 1~4 个字节的 FEH，用以唤醒接收方

Before sending frame information, transmit 1~4 bytes FEH to awaken the receiver

b) 传输次序

b) Transmission sequence

所有数据项均先传送低位字节，后传送高位字节。传送的数据项（除开关量）均为实际数据的压缩 BCD 码加上 33H。如外部主机读取 ACR220ELH/ACR320ELH 的正向有功电能仪表地址为 1：

All data will have the low bytes sent before the high bytes. All data transmitted (except for switch volume) are the compressed BCD code of actual data plus 33H, e.g. external host reading ACR220ELH/ACR320ELH forward active electric energy meter address 1:

主机发送：FE FE 68 01 00 00 00 00 00 68 01 02 43 C3 DA 16

Host sending: FE FE 68 01 00 00 00 00 00 68 01 02 43 C3 DA 16

ACR220ELH/ACR320ELH 应答 (0.40kWh) : 68 01 00 00 00 00 00 68 81 06 43 C3 73 33 33 33 6A 16

ACR220ELH/ACR320ELH response (0.40kWh) : 68 01 00 00 00 00 00 68 81 06 43 C3 73 33 33 33 6A 16

c) 传输响应

c) Transmission response

每次通讯都是由主站向按信息帧地址域选择的从站发送请求命令帧开始，被请求的从站根据命令帧中控制码的要求作出响应。

Each communication starts when the host station sends request command frame to the slave station determined according to the information frame address field and the requested slave station makes response according to the control code of the command frame.

收到命令帧后的响应延时

Response delay after receiving order frame: $\leq 500\text{ms}$

字节之间的停顿时间： ≤ 6 个字节的发送时间，当超过此时间时，ACR220ELH/ACR320ELH 认为是一新的数据帧。

Pause between bytes: ≤ 6 bytes sending time; when such specified time is exceeded, ACR220ELH/ACR320ELH is deemed as the new data frame.

d) 差错控制

d) Error control

字节校验为偶校验，帧校验为纵向信息校验和，接收方无论检测到偶校验或纵向信息校验和出错，均放弃该信息帧，不予响应。

Byte calibration is the even calibration while the frame calibration means longitudinal information calibration sum; in case of detecting even calibration or longitudinal information calibration and error, the receiver will reject the corresponding information frame without making response.

e) 传输速率

e) Transmission speed

初始速率为：9600bps

Initial speed: 9600bps

可设置为：1200、2400、4800、9600、19200bps

Set as: 1200, 2400, 4800, 9600, 19200bps

9.3.3 数据标识表

9.3.3 Data label table

表格 Table 1

序号 S/N	变量名 Variables	发送样例（以广播地址为例，用户可根据实际需求设定，地址高位用“00000000”填充） Send example (take broadcast address as an example, the user may conduct setting according to actual demand, address high bit filled by "00000000")	返回字节数 Return bytes	返回数据格式（二次测） Return data format (secondary side)	返回数据单位
1	正向有功电能 Forward active electric energy	68 99 99 99 99 99 99 68 01 02 43 C3 6F 16	4	XXXXXX. XX	kWh
2	反向有功电能 Backward active electric energy	68 99 99 99 99 99 99 68 01 02 53 C3 7F 16	4	XXXXXX. XX	kWh
3	正向无功电能 Forward passive electric energy	68 99 99 99 99 99 99 68 01 02 43 C4 70 16	4	XXXXXX. XX	kvarh
4	反向无功电能 Backward passive electric energy	68 99 99 99 99 99 99 68 01 02 53 C4 80 16	4	XXXXXX. XX	kvarh
5	A相电压 Phase A voltage	68 99 99 99 99 99 99 68 01 02 44 E9 96 16	2	XXX	V
6	B相电压 Phase B voltage	68 99 99 99 99 99 99 68 01 02 45 E9 97 16	2	XXX	V
7	C相电压 Phase C voltage	68 99 99 99 99 99 99 68 01 02 46 E9 98 16	2	XXX	V
8	A相谐波电压 Phase A harmonic voltage	68 99 99 99 99 99 99 68 01 02 47 E9 99 16	2	XXX	V
9	B相谐波电压 Phase B harmonic voltage	68 99 99 99 99 99 99 68 01 02 48 E9 9A 16	2	XXX	V
10	C相谐波电压 Phase C harmonic voltage	68 99 99 99 99 99 99 68 01 02 49 E9 9B 16	2	XXX	V
11	电压矢量和 Voltage vector sum	68 99 99 99 99 99 99 68 01 02 4A E9 9C 16	2	XXX	V
12	电网频率 Power grid frequency	68 99 99 99 99 99 99 68 01 02 4B E9 9D 16	2	XX. XX	Hz
13	A相电流 Phase A current	68 99 99 99 99 99 99 68 01 02 54 E9 A6 16	2	XX. XX	A
14	B相电流 Phase B current	68 99 99 99 99 99 99 68 01 02 55 E9 A7 16	2	XX. XX	A

15	C 相电流 Phase C current	68 99 99 99 99 99 99 68 01 02 56 E9 A8 16	2	XX. XX	A
16	A 相谐波电流 Phase A harmonic current	68 99 99 99 99 99 99 68 01 02 57 E9 A9 16	2	XX. XX	A
17	B 相谐波电流 Phase B harmonic current	68 99 99 99 99 99 99 68 01 02 58 E9 AA 16	2	XX. XX	A
18	C 相谐波电流 Phase C harmonic current	68 99 99 99 99 99 99 68 01 02 59 E9 AB 16	2	XX. XX	A
19	电流矢量和 Current vector sum	68 99 99 99 99 99 99 68 0102 5A E9 AC 16	2	XX. XX	A
20	合相有功功率 Conjunction active power	68 99 99 99 99 99 99 68 01 02 63 E9 B5 16	3	XX. XXXX	kW
21	A 相有功功率 Phase A active power	68 99 99 99 99 99 99 68 01 02 64 E9 B6 16	3	XX. XXXX	kW
22	B 相有功功率 Phase B active power	68 99 99 99 99 99 99 68 01 02 65 E9 B7 16	3	XX. XXXX	kW
23	C 相有功功率 Phase C active power	68 99 99 99 99 99 99 68 01 02 66 E9 B8 16	3	XX. XXXX	kW
24	合相无功功率 Conjunction reactive power	68 99 99 99 99 99 99 68 01 02 73 E9 C5 16	2	XX. XX	kvar
25	A 相无功功率 Phase A reactive power	68 99 99 99 99 99 99 68 01 02 74 E9 C6 16	2	XX. XX	kvar
26	B 相无功功率 Phase B reactive power	68 99 99 99 99 99 99 68 01 02 75 E9 C7 16	2	XX. XX	kvar
27	C 相无功功率 Phase C reactive power	68 99 99 99 99 99 99 68 01 02 76 E9 C8 16	2	XX. XX	kvar
28	合相功率因数 Conjunction power factor	68 99 99 99 99 99 99 68 01 02 83 E9 D5 16	2	X. XXX	
29	A 相功率因数 Phase A power factor	68 99 99 99 99 99 99 68 01 02 84 E9 D6 16	2	X. XXX	
30	B 相功率因数 Phase B power	68 99 99 99 99 99 99 68 01 02 85 E9 D7 16	2	X. XXX	

	factor				
31	C 相功率因数 Phase C power factor	68 99 99 99 99 99 99 68 01 02 86 E9 D8 16	2	X. XXX	
32	读取日期 Reading date	68 99 99 99 99 99 99 68 01 02 43 F3 9F 16	4	YYMMDDWW	WW=00
33	读取时间 Reading time	68 99 99 99 99 99 99 68 01 02 44 F3 A0 16	3	hhmmss	
34	开关量状态值 Switch state value	68 99 99 99 99 99 99 68 01 02 56 F3 B2 16	1		见附 See attachment 1
35	电压倍率 Voltage rate	68 99 99 99 99 99 99 68 01 02 68 F3 C4 16	2	XXXX	
36	电流倍率 Current rate	68 99 99 99 99 99 99 68 01 02 69 F3 C5 16	2	XXXX	
37	清开关量输出 Switch output	68 99 99 99 99 99 99 68 04 03 56 F3 00 B6 16	0		开关量输出共有 4 路 DO1-D04 The total switch volume output has 4 ways:: DO1-D04
38	设置 DO1 Set DO1	68 99 99 99 99 99 99 68 04 03 56 F3 01 B7 16	0		
39	设置 DO2 Set DO2	68 99 99 99 99 99 99 68 04 03 56 F3 02 B8 16	0		
40	设置 DO1、DO2 Set DO1, DO2	68 99 99 99 99 99 99 68 04 03 56 F3 03 B9 16	0		

附 Attachment 1:

Bit7	Bit6	Bit5	Bit4	Bit3	Bit2	Bit1	Bit0
DI1	DI2	DI3	DI4	DO1	DO2	DO3	DO4

10 平均值、极值、不平衡度相关说明

10.1 按键操作指南 Key operation guide

按 SET 键切换到 PASS 界面，密码输入正确后按回车键进入菜单编程界面。按左、右键可切换到 FUN（功能）选项，在 FUN（功能）选项按回车键，再按左、右键可选择 FUN1 或 FUN2。在 FUN1 按回车键即可查看平均值、极值相关的界面，按左、右键可切换显示：平均值 ↔ 相电压最大值 ↔ 相电压最小值 ↔ 线电压最大值 ↔ 线电压最小值 ↔ 电流最大值 ↔ 电流最小值 ↔ 总功率最大值 ↔ 总功率最小值 ↔ 有功功率最大值 ↔ 有功功率最小值 ↔ 无功功率最大值 ↔ 无功功率最小值 ↔ 视在功率最大值 ↔ 视在功率最小值 ↔ 功率因数最大值 ↔ 功率因数最小值 ↔ 总功率因数、中心线电流、频率最大值 ↔ 总功率因数、中心线电流、频率最小值 ↔ 电压总谐波含量（THD）最大值 ↔ 电压总谐波含量（THD）最小值 ↔ 电流总谐波含量（THD）最大值 ↔ 电流总谐波含量（THD）最小值。

10 Explanation of average value , extremum、unbalance

Press the SET key to switch to PASS interface, after entering the correct password and press Enter key to access the menu programming interface. Press the left, right switch to FUN (function) option, press the Enter key to enter FUN1 to see average extremes associated interface, press left, right can switch: the average ↔ phasevoltage maximum ↔ phasevoltage minimum ↔ line voltage maximum ↔ line voltage minimum ↔ current maximum ↔ current minimum ↔ total power maximum ↔ total power minimum ↔ active power maximum ↔ active power minimum ↔ reactive power maximum ↔ reactive power minimum ↔ apparent power maximum ↔ apparent power minimum ↔ power factor maximum ↔ power factor minimum ↔ total power factor, the center line of current, frequency maximum ↔ voltage total harmonic content (THD) maximum ↔ voltage total harmonic content (THD) minimum ↔ current total harmonic content (THD) maximum ↔ current total harmonic content (THD) minimum.



FUN1 (功能) 选项相关界面 Interfaces of FUN1 (function) option

在 FUN2 按回车键即可查看电压电流不平衡度 (UF)。

Press the ENTER key in FUN2 interfaceto view the unbalance of voltage and current(UF).

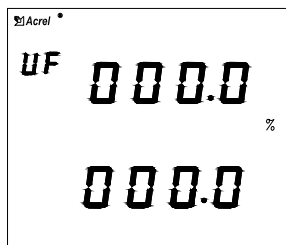

FUN2 (功能) 选项相关界面 Interface of FUN2 (function) option

10.2 通讯说明 Communication description

3000 高字节 High byte	小数点 U (DPT) Decimal point U (DPT)	RO	3-7	0.5
3000 低字节 Low byte	小数点 I (DCT) Decimal point I (DCT)	RO	1-5	0.5
3001 高字节 High byte	小数点 PQ (DPQ) Decimal point PQ(DPQ)	RO	4-10	0.5
3001 低字节 Low byte	符号 PQ Symbol PQ	RO	高位-低位 high bit-low bit: Q、Qc、Qb、Qa、P、Pc、Pb、Pa 0 为正, 1 为负 0 is positive, 1 is negative	0.5
3002	相电压平均值 Phase voltage average	RO	一次侧 primary side	1
3003	线电压平均值 Line voltage average	RO	一次侧 primary side	1
3004	电流平均值 Current average	RO	一次侧 primary side	1
3008-3009	系统运行时间 System uptime	R/W	以秒为单位, 高字节在前, 低字节在后 In seconds, the high byte before, and the low byte in the back.	2
3010	相电压 Uan 最大值 phase voltage Uanmaximum	RO	一次侧 primary side	1
3011	发生时刻: 年、月 Generation time: year、month	RO	高 8 位: 年; 低 8 位: 月 High 8: year ; low 8: month	1
3012	发生时刻: 日、时 Generation time: day,hour	RO	高 8 位: 日; 低 8 位: 时 High 8: day ; low 8: hour	1
3013	发生时刻: 分、秒 Generation time: minutes, seconds	RO	高 8 位: 分; 低 8 位: 秒 High 8: minutes ; low 8: seconds	1
3014	相电压 Ubn 最大值 phase voltage Ubnmaximum	RO	一次侧 primary side	1
3015	发生时刻: 年、月 Generation time: year、month	RO	高 8 位: 年; 低 8 位: 月 High 8: year ; low 8: month	1
3016	发生时刻: 日、时	RO	高 8 位: 日; 低 8 位: 时	1

	Generation time: day, hour		High 8: day ; low 8: hour	
3017	发生时刻: 分、秒 Generation time: minutes, seconds	RO	高 8 位: 分; 低 8 位: 秒 High 8: minutes ; low 8: seconds	1
3018	相电压 Ucn 最大值 phase voltage Ucn maximum	RO	一次侧 primary side	1
3019	发生时刻: 年、月 Generation time: year, month	RO	高 8 位: 年; 低 8 位: 月 High 8: year ; low 8: month	1
3020	发生时刻: 日、时 Generation time: day, hour	RO	高 8 位: 日; 低 8 位: 时 High 8: day ; low 8: hour	1
3021	发生时刻: 分、秒 Generation time: minutes, seconds	RO	高 8 位: 分; 低 8 位: 秒 High 8: minutes ; low 8: seconds	1
3022	线电压 Uab 最大值 line voltage Uab maximum	RO	一次侧 primary side	1
3023	发生时刻: 年、月 Generation time: year, month	RO	高 8 位: 年; 低 8 位: 月 High 8: year ; low 8: month	1
3024	发生时刻: 日、时 Generation time: day, hour	RO	高 8 位: 日; 低 8 位: 时 High 8: day ; low 8: hour	1
3025	发生时刻: 分、秒 Generation time: minutes, seconds	RO	高 8 位: 分; 低 8 位: 秒 High 8: minutes ; low 8: seconds	1
3026	线电压 Ubc 最大值 line voltage Ubc maximum	RO	一次侧 primary side	1
3027	发生时刻: 年、月 Generation time: year, month	RO	高 8 位: 年; 低 8 位: 月 High 8: year ; low 8: month	1
3028	发生时刻: 日、时 Generation time: day, hour	RO	高 8 位: 日; 低 8 位: 时 High 8: day ; low 8: hour	1
3029	发生时刻: 分、秒 Generation time: minutes, seconds	RO	高 8 位: 分; 低 8 位: 秒 High 8: minutes ; low 8: seconds	1
3030	线电压 Uca 最大值 line voltage Uca maximum	RO	一次侧 primary side	1
3031	发生时刻: 年、月 Generation time: year, month	RO	高 8 位: 年; 低 8 位: 月 High 8: year ; low 8: month	1
3032	发生时刻: 日、时 Generation time:	RO	高 8 位: 日; 低 8 位: 时 High 8: day ; low 8: hour	1

	day, hour			
3033	发生时刻: 分、秒 Generation time: minutes, seconds	RO	高 8 位: 分; 低 8 位: 秒 High 8: minutes ; low 8: seconds	1
3034	相电流 Ia 最大值 Phase Current Ia maximum	RO	一次侧 primary side	1
3035	发生时刻: 年、月 Generation time: year, month	RO	高 8 位: 年; 低 8 位: 月 High 8: year ; low 8: month	1
3036	发生时刻: 日、时 Generation time: day, hour	RO	高 8 位: 日; 低 8 位: 时 High 8: day ; low 8: hour	1
3037	发生时刻: 分、秒 Generation time: minutes, seconds	RO	高 8 位: 分; 低 8 位: 秒 High 8: minutes ; low 8: seconds	1
3038	相电流 Ib 最大值 Phase Current Ib maximum	RO	一次侧 primary side	1
3039	发生时刻: 年、月 Generation time: year, month	RO	高 8 位: 年; 低 8 位: 月 High 8: year ; low 8: month	1
3040	发生时刻: 日、时 Generation time: day, hour	RO	高 8 位: 日; 低 8 位: 时 High 8: day ; low 8: hour	1
3041	发生时刻: 分、秒 Generation time: minutes, seconds	RO	高 8 位: 分; 低 8 位: 秒 High 8: minutes ; low 8: seconds	1
3042	相电流 Ic 最大值 Phase Current Ic maximum	RO	一次侧 primary side	1
3043	发生时刻: 年、月 Generation time: year, month	RO	高 8 位: 年; 低 8 位: 月 High 8: year ; low 8: month	1
3044	发生时刻: 日、时 Generation time: day, hour	RO	高 8 位: 日; 低 8 位: 时 High 8: day ; low 8: hour	1
3045	发生时刻: 分、秒 Generation time: minutes, seconds	RO	高 8 位: 分; 低 8 位: 秒 High 8: minutes ; low 8: seconds	1
3046	A 相有功功率 Pa 最大值 A active power Pa maximum	RO	一次侧 primary side	1
3047	发生时刻: 年、月 Generation time: year, month	RO	高 8 位: 年; 低 8 位: 月 High 8: year ; low 8: month	1
3048	发生时刻: 日、时 Generation time: day, hour	RO	高 8 位: 日; 低 8 位: 时 High 8: day ; low 8: hour	1

3049	发生时刻：分、秒 Generation time: minutes, seconds	RO	高 8 位：分；低 8 位：秒 High 8: minutes ; low 8: seconds	1
3050	B 相有功功率 Pb 最大值 B active power Pb maximum	RO	一次侧 primary side	1
3051	发生时刻：年、月 Generation time: year、month	RO	高 8 位：年；低 8 位：月 High 8: year ; low 8: month	1
3052	发生时刻：日、时 Generation time: day,hour	RO	高 8 位：日；低 8 位：时 High 8: day ; low 8: hour	1
3053	发生时刻：分、秒 Generation time: minutes, seconds	RO	高 8 位：分；低 8 位：秒 High 8: minutes ; low 8: seconds	1
3054	C 相有功功率 Pc 最大值 C active power Pc maximum	RO	一次侧 primary side	1
3055	发生时刻：年、月 Generation time: year、month	RO	高 8 位：年；低 8 位：月 High 8: year ; low 8: month	1
3056	发生时刻：日、时 Generation time: day,hour	RO	高 8 位：日；低 8 位：时 High 8: day ; low 8: hour	1
3057	发生时刻：分、秒 Generation time: minutes, seconds	RO	高 8 位：分；低 8 位：秒 High 8: minutes ; low 8: seconds	1
3058	总有功功率 P 总最大值 Total active power P maximum	RO	一次侧 primary side	1
3059	发生时刻：年、月 Generation time: year、month	RO	高 8 位：年；低 8 位：月 High 8: year ; low 8: month	1
3060	发生时刻：日、时 Generation time: day,hour	RO	高 8 位：日；低 8 位：时 High 8: day ; low 8: hour	1
3061	发生时刻：分、秒 Generation time: minutes, seconds	RO	高 8 位：分；低 8 位：秒 High 8: minutes ; low 8: seconds	1
3062	A 相无功功率 Qa 最大值 Phase A Reactive power Qamaximum	RO	一次侧 primary side	1
3063	发生时刻：年、月 Generation time: year、month	RO	高 8 位：年；低 8 位：月 High 8: year ; low 8: month	1
3064	发生时刻：日、时 Generation time: day,hour	RO	高 8 位：日；低 8 位：时 High 8: day ; low 8: hour	1

3065	发生时刻：分、秒 Generation time: minutes, seconds	RO	高 8 位：分；低 8 位：秒 High 8: minutes ; low 8: seconds	1
3066	B 相无功功率 Qb 最大值 Phase B Reactive power Qb maximum	RO	一次侧 primary side	1
3067	发生时刻：年、月 Generation time: year、month	RO	高 8 位：年；低 8 位：月 High 8: year ; low 8: month	1
3068	发生时刻：日、时 Generation time: day, hour	RO	高 8 位：日；低 8 位：时 High 8: day ; low 8: hour	1
3069	发生时刻：分、秒 Generation time: minutes, seconds	RO	高 8 位：分；低 8 位：秒 High 8: minutes ; low 8: seconds	1
3070	C 相无功功率 Qc 最大值 Phase C Reactive power Qc maximum	RO	一次侧 primary side	1
3071	发生时刻：年、月 Generation time: year、month	RO	高 8 位：年；低 8 位：月 High 8: year ; low 8: month	1
3072	发生时刻：日、时 Generation time: day, hour	RO	高 8 位：日；低 8 位：时 High 8: day ; low 8: hour	1
3073	发生时刻：分、秒 Generation time: minutes, seconds	RO	高 8 位：分；低 8 位：秒 High 8: minutes ; low 8: seconds	1
3074	总无功功率 Q 总最大值 Total.Reactive power QTotalmaximum	RO	一次侧 primary side	1
3075	发生时刻：年、月 Generation time: year、month	RO	高 8 位：年；低 8 位：月 High 8: year ; low 8: month	1
3076	发生时刻：日、时 Generation time: day, hour	RO	高 8 位：日；低 8 位：时 High 8: day ; low 8: hour	1
3077	发生时刻：分、秒 Generation time: minutes, seconds	RO	高 8 位：分；低 8 位：秒 High 8: minutes ; low 8: seconds	1
3078	A 相视在功率 Sa 最大值 Phase A Apparent power Samaximum	RO	一次侧 primary side	1
3079	发生时刻：年、月 Generation time: year、month	RO	高 8 位：年；低 8 位：月 High 8: year ; low 8: month	1

3080	发生时刻：日、时 Generation time: day, hour	RO	高 8 位：日；低 8 位：时 High 8: day ; low 8: hour	1
3081	发生时刻：分、秒 Generation time: minutes, seconds	RO	高 8 位：分；低 8 位：秒 High 8: minutes ; low 8: seconds	1
3082	B 相视在功率 Sb 最大值 Phase B Apparent powerSb maximum	RO	一次侧 primary side	1
3083	发生时刻：年、月 Generation time: year、month	RO	高 8 位：年；低 8 位：月 High 8: year ; low 8: month	1
3084	发生时刻：日、时 Generation time: day, hour	RO	高 8 位：日；低 8 位：时 High 8: day ; low 8: hour	1
3085	发生时刻：分、秒 Generation time: minutes, seconds	RO	高 8 位：分；低 8 位：秒 High 8: minutes ; low 8: seconds	1
3086	C 相视在功率 Sc 最大值 Phase C Apparent powerSc maximum	RO	一次侧 primary side	1
3087	发生时刻：年、月 Generation time: year、month	RO	高 8 位：年；低 8 位：月 High 8: year ; low 8: month	1
3088	发生时刻：日、时 Generation time: day, hour	RO	高 8 位：日；低 8 位：时 High 8: day ; low 8: hour	1
3089	发生时刻：分、秒 Generation time: minutes, seconds	RO	高 8 位：分；低 8 位：秒 High 8: minutes ; low 8: seconds	1
3090	总视在功率 S 总最大值 TotalApparent power STotalmaximum	RO	一次侧 primary side	1
3091	发生时刻：年、月 Generation time: year、month	RO	高 8 位：年；低 8 位：月 High 8: year ; low 8: month	1
3092	发生时刻：日、时 Generation time: day, hour	RO	高 8 位：日；低 8 位：时 High 8: day ; low 8: hour	1
3093	发生时刻：分、秒 Generation time: minutes, seconds	RO	高 8 位：分；低 8 位：秒 High 8: minutes ; low 8: seconds	1
3094	A 相功率因数最大值 Phase A power factormaximum	RO	功率因数 小数点位数：3 power factor.decimal Point digital:3	1

3095	发生时刻：年、月 Generation time: year、month	RO	高 8 位：年；低 8 位：月 High 8: year ; low 8: month	1
3096	发生时刻：日、时 Generation time: day,hour	RO	高 8 位：日；低 8 位：时 High 8: day ; low 8: hour	1
3097	发生时刻：分、秒 Generation time: minutes, seconds	RO	高 8 位：分；低 8 位：秒 High 8: minutes ; low 8: seconds	1
3098	B 相功率因数最大值 Phase B power factormaximum	RO		1
3099	发生时刻：年、月 Generation time: year、month	RO	高 8 位：年；低 8 位：月 High 8: year ; low 8: month	1
3100	发生时刻：日、时 Generation time: day,hour	RO	高 8 位：日；低 8 位：时 High 8: day ; low 8: hour	1
3101	发生时刻：分、秒 Generation time: minutes, seconds	RO	高 8 位：分；低 8 位：秒 High 8: minutes ; low 8: seconds	1
3102	C 相功率因数最大值 Phase C power factormaximum	RO		1
3103	发生时刻：年、月 Generation time: year、month	RO	高 8 位：年；低 8 位：月 High 8: year ; low 8: month	1
3104	发生时刻：日、时 Generation time: day,hour	RO	高 8 位：日；低 8 位：时 High 8: day ; low 8: hour	1
3105	发生时刻：分、秒 Generation time: minutes, seconds	RO	高 8 位：分；低 8 位：秒 High 8: minutes ; low 8: seconds	1
3106	频率 F 最大值 Frequencymaximum	RO	频率小数点位数：2 Frequency decimalPoint digital:2	1
3107	发生时刻：年、月 Generation time: year、month	RO	高 8 位：年；低 8 位：月 High 8: year ; low 8: month	1
3108	发生时刻：日、时 Generation time: day,hour	RO	高 8 位：日；低 8 位：时 High 8: day ; low 8: hour	1
3109	发生时刻：分、秒 Generation time: minutes, seconds	RO	高 8 位：分；低 8 位：秒 High 8: minutes ; low 8: seconds	1
3110	中性线电流最大值	RO	二次侧 电流小数点位数：3	1

			Secondary side Current decimal Point digital:3	
3111	发生时刻: 年、月 Generation time: year、month	RO	高 8 位: 年; 低 8 位: 月 High 8: year ; low 8: month	1
3112	发生时刻: 日、时 Generation time: day,hour	RO	高 8 位: 日; 低 8 位: 时 High 8: day ; low 8: hour	1
3113	发生时刻: 分、秒 Generation time: minutes, seconds	RO	高 8 位: 分; 低 8 位: 秒 High 8: minutes ; low 8: seconds	1
3114	A 相电压总谐波畸变率最大值 A Phase Voltage Total harmonic distortionmaximum	RO	A 相电压总谐波含量;小数点位数: 2 A Phase Voltage Total harmonic content;decimal point digital:2	1
3115	发生时刻: 年、月 Generation time: year、month	RO	高 8 位: 年; 低 8 位: 月 High 8: year ; low 8: month	1
3116	发生时刻: 日、时 Generation time: day,hour	RO	高 8 位: 日; 低 8 位: 时 High 8: day ; low 8: hour	1
3117	发生时刻: 分、秒 Generation time: minutes, seconds	RO	高 8 位: 分; 低 8 位: 秒 High 8: minutes ; low 8: seconds	1
3118	B 相电压总谐波畸变率最大值 B Phase Voltage Total harmonic distortionmaximum	RO	B 相电压总谐波含量;小数点位数: 2 B Phase Voltage Total harmonic content;decimal point digital:2	1
3119	发生时刻: 年、月 Generation time: year、month	RO	高 8 位: 年; 低 8 位: 月 High 8: year ; low 8: month	1
3120	发生时刻: 日、时 Generation time: day,hour	RO	高 8 位: 日; 低 8 位: 时 High 8: day ; low 8: hour	1
3121	发生时刻: 分、秒 Generation time: minutes, seconds	RO	高 8 位: 分; 低 8 位: 秒 High 8: minutes ; low 8: seconds	1
3122	C 相电压总谐波畸变率最大值 C Phase Voltage Total harmonic distortionmaximum	RO	C 相电压总谐波含量;小数点位数: 2 C Phase Voltage Total harmonic content;decimal point digital:2	1
3123	发生时刻: 年、月 Generation time: year、month	RO	高 8 位: 年; 低 8 位: 月 High 8: year ; low 8: month	1
3124	发生时刻: 日、时 Generation time: day,hour	RO	高 8 位: 日; 低 8 位: 时 High 8: day ; low 8: hour	1
3125	发生时刻: 分、秒	RO	高 8 位: 分; 低 8 位: 秒	1

	Generation time: minutes, seconds		High 8: minutes ; low 8: seconds	
3126	A 相电流总谐波畸变率最大值 A Phase Current Total harmonic distortionmaximum	RO	A 相电流总谐波含量;小数点位数: 2 A Phase Current Total harmonic content;decimal point digital:2	1
3127	发生时刻: 年、月 Generation time: year、month	RO	高 8 位: 年; 低 8 位: 月 High 8: year ; low 8: month	1
3128	发生时刻: 日、时 Generation time: day,hour	RO	高 8 位: 日; 低 8 位: 时 High 8: day ; low 8: hour	1
3129	发生时刻: 分、秒 Generation time: minutes, seconds	RO	高 8 位: 分; 低 8 位: 秒 High 8: minutes ; low 8: seconds	1
3130	B 相电流总谐波畸变率最大值 B Phase Current Total harmonic distortionmaximum	RO	B 相电流总谐波含量;小数点位数: 2 B Phase Current Total harmonic content;decimal point digital:2	1
3131	发生时刻: 年、月 Generation time: year、month	RO	高 8 位: 年; 低 8 位: 月 High 8: year ; low 8: month	1
3132	发生时刻: 日、时 Generation time: day,hour	RO	高 8 位: 日; 低 8 位: 时 High 8: day ; low 8: hour	1
3133	发生时刻: 分、秒 Generation time: minutes, seconds	RO	高 8 位: 分; 低 8 位: 秒 High 8: minutes ; low 8: seconds	1
3134	C 相电流总谐波畸变率最大值 C Phase Current Total harmonic distortionmaximum	RO	C 相电流总谐波含量;小数点位数: 2 C Phase Current Total harmonic content;decimal point digital:2	1
3135	发生时刻: 年、月 Generation time: year、month	RO	高 8 位: 年; 低 8 位: 月 High 8: year ; low 8: month	1
3136	发生时刻: 日、时 Generation time: day,hour	RO	高 8 位: 日; 低 8 位: 时 High 8: day ; low 8: hour	1
3137	发生时刻: 分、秒 Generation time: minutes, seconds	RO	高 8 位: 分; 低 8 位: 秒 High 8: minutes ; low 8: seconds	1

11 以太网设置 Ethernet network settings

11.1 网络设置 Network settings

首先进入操作系统，使用鼠标点击任务栏的“开始”“设置”“控制面板”（或在“我的电脑”里面直接打开“控制面板”），双击“网络和拨号连接”（或“网络连接”）图标，您会看到下图所示的页面。请按其所示，选择“使用下面的 IP 地址”，并填入 IP 地址 192.168.0.55，子网掩码 255.255.255.0，默认网关 192.168.0.1（DNS 部分可以不填）。点击该页面的“确定”及“本地连接属性”页面的确定，等待系统配置完毕。

First enter the operating system, use the mouse to click on the taskbar "Start""Settings""Control Panel" (or open the "Control Panel" directly inside "My Computer"), double-click "Network and dial-up connection" (or "Network connection") icon, you will see the page shown below. Please select "Use the following IP address" as shown, and fill in the IP address 192.168.0.55, the subnet mask 255.255.255.0, and the default gateway 192.168.0.1 (the DNS part can be omitted). Click "OK on" the page and click "OK" on the "Local Area Connection Properties" page to wait for system configuration to complete.

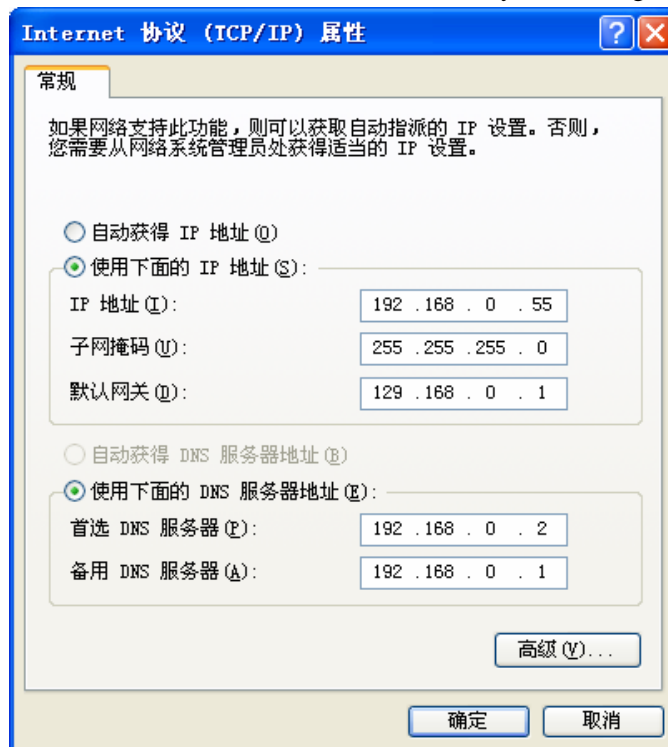

用双绞线 B 类网线连接以太网模块和电脑，给仪表通电。此时，电脑显示器中的右下角出现本地连接现已连接上，则可继续下一步操作。否则，仪表断电，检查网线，网络设置。

Connect the Ethernet module and the computer with a twisted-pair type B cable and power the meter. At this time, the local connection in the lower right corner of the computer monitor is now connected, you can continue to the next step. Otherwise, power off the instrument, check the network cable, and network settings.

11.2 WEB 网页配置 WEB page configuration

11.2.1 登录网页配置系统 Login page configuration system

打开 IE 浏览器，在地址栏输入以太网 IP 地址 (http://192.168.0.178/)，出现下图所示的登录界面。

Open the IE browser and enter the Ethernet IP address (http://192.168.0.178/) in the address bar. The login page as shown in the figure below appears.

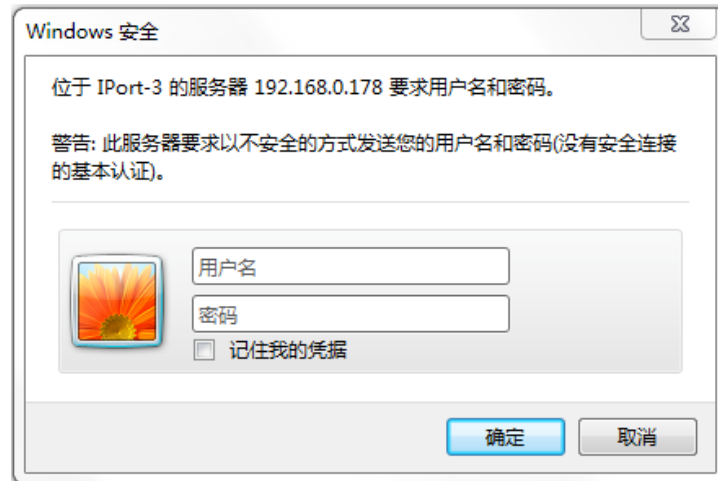

在【用户名】中输入“guest”，在【密码】中输入“88888”（出厂默认设置），然后点击 ，浏览器将自动进入下图所示的用户配置界面。

Enter “guest” in [User Name] and “88888” (factory default setting) in [Password], then click  , and the browser will automatically enter the user configuration interface shown in the figure below.



11.3 仪表设置 Instrument settings

以太网也可以通过仪表按键进行设置，设置界面如下。在设置完成后，需按回车键进行确认，确认完成后连续点按 SET 键直到出现 SAVE/YES 页面，此时必须按回车键确认，否则设置无效。

Ethernet can also be set via the meter buttons. The settings interface is as follows. After the setting

is completed, press the enter key to confirm. After confirmation, press the SET button continuously until the SAVE/YES page appears. At this time, press the enter key to confirm. Otherwise, the setting is invalid.

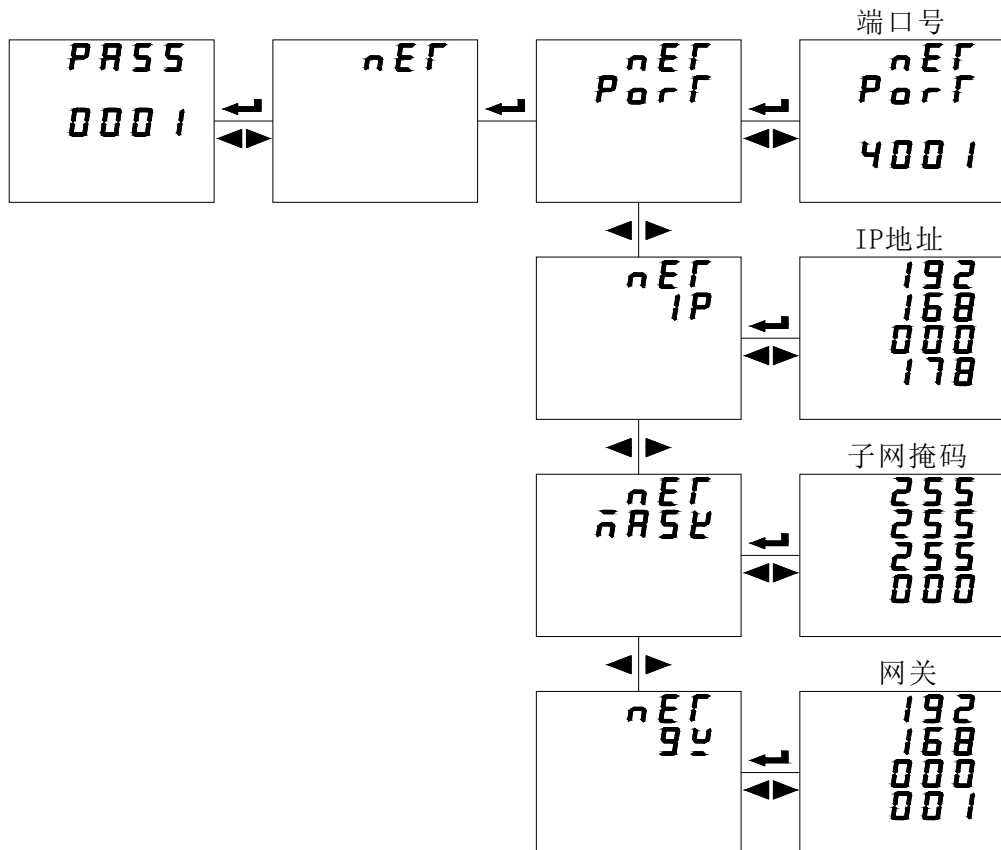

11.4 ModScan32 设置 ModScan32 settings

打开 ModScan32 软件，如下图所示设置。点击 Connect，选择 Remote TCP/IP Server

IP Address:以太网模块的 IP 地址

(如 192.168.0.178)

Serevice 端口号 4001

点击 OK 键即可。

Open the ModScan32 software and set it as shown below. Click Connect and select Remote TCP/IP Server.

IP Address:The IP address of the Ethernet module (eg 192.168.0.178)

Serevice Port number 4001

Click "OK".

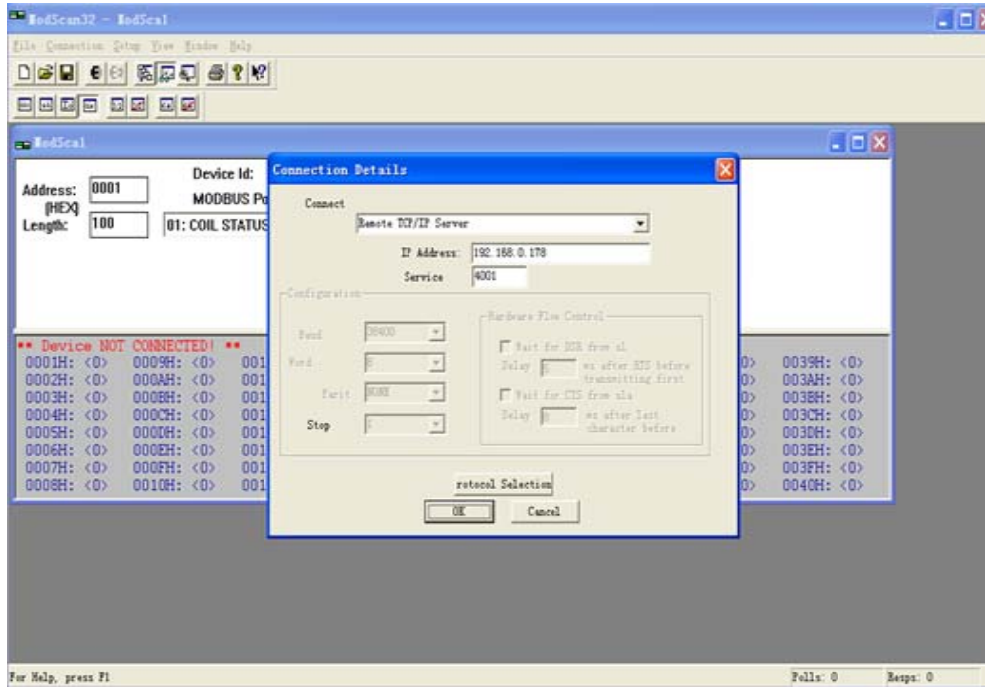

总部：安科瑞电气股份有限公司

地址：上海市嘉定马东工业园区育绿路 253 号

电话：(86)021-69158300 69158301 69158302

传真：(86)021-69158303

服务热线：800-820-6632

网址：www.acrel.cn

E-mail: ACREL001@vip.163.com

邮编：201801

Headquarter: Acrel Electrical Equipment Co., Ltd.

Address: No.253, Yulv Road, Madong Industrial Park Zone, Jiading District, Shanghai City.

Tel: (86)021-69158300 69158301 69158302

Fax: (86)021-69158303

Service hotline: 800-820-6632

URL: www.acrel.cn

E-mail: ACREL001@vip.163.com

Zip code: 201801

生产基地：江苏安科瑞电器制造有限公司

地址：江阴市南闸街道东盟路 5 号

电话(传真)：(86)0510-86179970

邮编：214405

E-mail: JY-ACREL001@vip.163.com

Production base: Jiangsu Acrel Electrical Equipment Manufacturing Co., Ltd.

Address: No.5, Dongmeng Road, Dongmeng Industrial Park Zone, Nanzha Town, Jiangyin City.

Tel(Fax):(86) 0510-86179970

Zip code: 214405

E-mail: JY-ACREL001@vip.163.com

更改记录:

1.1: 修改 ACR230ELH 和 ACR330ELH 部分的图形界面及说明;

增加 11 章节以太网设置;

2.2 产品辅助功能将 2 系列和 3 系列整合。

1.2: 2.1、7.1.3、7.2.2 增加电压角度和电流角度功能及相关界面菜单说明, 230、320 支持电压电流不平衡度;

2.1 系列产品规格增加中性线电流选项;

更正 8.3.1、8.3.2、8.3.3、8.3.4、8.3.5 中举例的参数地址;

8.3.6 中事件记录地址 2 的报警类型更正为见 7.1.5;

10.1 按键操作指南增加查看电压电流不平衡度 (UF) 的操作方法;

2.1 系列产品规格分次谐波改为 2~63 次;

7.2.9 用户设置电压等级改为 (100V、400V、660V)。